

# VALOR FIRES

## INSTALLER AND OWNER GUIDE

### Model 752

INSET LIVE FUEL EFFECT GAS FIRE

Fitted with a

**Broadway, Liberty,  
Valor Landscape 2 Gas or  
Vermont** fascia

(GC No. 32-032-74)



We trust that this guide gives sufficient details to enable this appliance to be installed, operated and maintained satisfactorily.

However, if further information is required, our

**Valor Fires Technical Helpline** will be pleased to help.

Telephone **0844 8711 565** (National call rates apply in the United Kingdom).

In the Republic of Ireland

Telephone **0044 844 8711 565**.



**BAXI • VALOR • WONDERFIRE**

**INSTALLER: Please leave this guide with the owner**

**THIS APPLIANCE IS FOR USE WITH NATURAL GAS (G20).**

**WHEN CONVERTED USING CONVERSION KIT NO. 0595221 THIS APPLIANCE  
IS FOR USE WITH PROPANE GAS (G31).**

**THIS APPLIANCE IS SUITABLE ONLY FOR INSTALLATION IN THE UNITED  
KINGDOM (GB) AND THE REPUBLIC OF IRELAND (IE).**

**© Baxi Heating U.K. Limited 2010.**

All rights reserved. No part of this publication may be reproduced in any material form (including photocopying), stored in any medium by electronic means (including in any retrieval system or database) or transmitted, in any form or by any means, whether electronic, mechanical, recording or otherwise, without the prior written permission of the copyright owner.

Applications for the copyright owner's permission to reproduce any part of this publication should be made, giving details of the proposed use, to the following address: The Company Secretary, Baxi Heating UK Limited, The Wyvern Business Park, Stanier Way, Derby, DE21 6BF.

Warning: Any person who does any unauthorised act in relation to a copyright work may be liable to criminal prosecution and civil claims for damages.

**VALOR FIRES**

Valor Fires, Erdington, Birmingham B24 9QP  
[www.firesandstoves.co.uk](http://www.firesandstoves.co.uk)

Because our policy is one of constant development and improvement, details may vary slightly from those given in this publication

## **Safety First.**

Valor Fires fires are CE Approved and designed to meet the appropriate British Standards and Safety Marks.



## **Quality and Excellence.**

All Valor Fires fires are manufactured to the highest standards of quality and excellence and are manufactured under a BS EN ISO 9001 quality system accepted by the British Standards Institute.



## **The Highest Standards**

Valor Fires is a member of SBGI and HHIC (Heating and Hot water Industry Council) that work to ensure high standards of safety, quality and performance.



## **Careful Installation**

This gas fires must be installed by a competent GAS SAFE REGISTER engineer (GAS SAFE REGISTER or CORGI engineer outside of UK) in accordance with our installer guide and should not be fitted directly on to a carpet or floor of combustible material.



# INSTALLER GUIDE

FOR OWNER GUIDE SEE PAGES 35 TO 47

# INSTALLER GUIDE

## CONTENTS

<u>Section</u>	<u>Heading</u>	<u>Page</u>
	<b>INSTALLER GUIDE</b>	<b>4 - 34</b>
	<b>OWNER GUIDE</b>	<b>35 - 47</b>
<b>1.</b>	<b>SAFETY AND UNPACKING</b>	<b>7</b>
<b>2.</b>	<b>APPLIANCE DATA AND EFFICIENCY</b>	<b>8</b>
	2.1 General information.	8
	2.2 Efficiency.	8
<b>3.</b>	<b>GENERAL INSTALLATION REQUIREMENTS</b>	<b>9</b>
	3.1 Regulations, Standards and Law.	9
	3.2 Ventilation requirements.	10
	3.3 The Atmosphere sensing device (ASD).	10
	3.4 Fireguard requirements.	10
	3.5 Room considerations.	10
	3.6 Chimney preparation.	10
	3.7 Fireplace preparation.	11
	3.8 The hearth.	11
	3.9 Fireplace clearances.	12
	3.10 Installation options.	14
	3.10.1 Conventional fireplace and hearth.	14
	3.10.1.1 'Hole-in-the-wall' Installations.	14
	3.10.2 Metal flue box and hearth.	15
	3.10.3 Precast concrete or clay flue block system and hearth.	16
	3.11 Flues.	17
	3.12 Propane gas fires.	17
<b>4.</b>	<b>PACK CONTENTS</b>	<b>18</b>
<b>5.</b>	<b>FIREPLACE CHECK</b>	<b>20</b>
	5.1 Soundness for appliance attachment.	20
	5.2 Fireplace flue pull.	20
<b>6.</b>	<b>IGNITION CHECK</b>	<b>20</b>
<b>7.</b>	<b>GAS SUPPLY CONNECTION</b>	<b>21</b>
<b>8.</b>	<b>PREPARING APPLIANCE FOR INSTALLATION</b>	<b>21</b>
	8.1 Appliance preparation.	21
	8.2 Fitting the foam seal.	22
	8.3 The flue restrictor.	22
<b>9.</b>	<b>HOTBOX INSTALLATION</b>	<b>23</b>
	9.1 Hotbox installation.	23
	9.2 Floor sealing (All Installations).	24

Continued on next page

# INSTALLER GUIDE

## CONTENTS (Continued)

<u>Section</u>	<u>Heading</u>	<u>Page</u>
<b>10.</b>	<b>BURNER INSTALLATION</b>	<b>25</b>
10.1	Burner and supply pipe installation.	25
10.2	Fitting the batteries.	25
10.3	Preliminary burner checks.	25
10.4	Lighting the pilot.	25
10.5	Checking the heat settings.	26
10.6	To turn the fire back to pilot setting.	26
10.7	To turn the fire off.	26
10.8	Using the remote control handset.	26
10.9	Inlet pressure check.	27
10.10	Fitting the burner tray trim.	27
<b>11.</b>	<b>FITTING THE CERAMIC FUEL EFFECT</b>	<b>27</b>
<b>12.</b>	<b>FASCIA INSTALLATION</b>	<b>28</b>
<b>13.</b>	<b>FULL OPERATING CHECKS</b>	<b>28</b>
<b>14.</b>	<b>SPILLAGE &amp; FLAME SUPERVISION CHECKS</b>	<b>29</b>
14.1	Check for spillage.	29
14.2	Flame supervision and spillage monitoring system.	29
<b>15.</b>	<b>FINAL REVIEW</b>	<b>30</b>
<b>16.</b>	<b>SERVICING &amp; PARTS REPLACEMENT</b>	<b>31</b>
16.1	Checking the aeration setting of the burner.	32
16.2	To remove the complete burner unit.	32
16.3	To remove the pilot unit.	33
16.4	To remove the gas valve.	33
16.5	To replace the burner.	34
16.6	To remove the main burner injector.	34
16.7	To remove the appliance from the fireplace.	34

# INSTALLER GUIDE

## 1. SAFETY AND UNPACKING

### Installer

Before continuing any further with the installation of this appliance please read the following guide to manual handling

- The lifting weight of this appliance is as below (kg):

<u>Model</u>	<u>Heat Engine</u>	<u>Firefront</u>	<u>Combined Weight</u>
Broadway	7.45	6.35	13.8
Valor Landscape 2 Gas	7.45	6.35	13.8
Vermont	7.45	6.26	13.71
Liberty	7.45	6.26	13.71

- One person should be sufficient to lift the fire. If for any reason this weight is considered too heavy then obtain assistance.
- When lifting always keep your back straight. Bend your legs and not your back.
- Avoid twisting at the waist. It is better to reposition your feet.
- Avoid upper body/top heavy bending. Do not lean forward or sideways whilst handling the fire.
- Always grip with the palm of the hand. Do not use the tips of fingers for support.
- Always keep the fire as close to the body as possible. This will minimise the cantilever action.
- Use gloves to provide additional grip.
- Always use assistance if required.

**This product uses fuel effect pieces and burner compartment rear wall containing Refractory Ceramic Fibres (RCF), which are man-made vitreous silicate fibres. Excessive exposure to these materials may cause irritation to eyes, skin and respiratory tract. Consequently, it is important to take care when handling these articles to ensure that the release of dust is kept to a minimum. To ensure that the release of fibres from these RCF articles is kept to a minimum, during installation and servicing we recommend that you use a HEPA filtered vacuum to remove any dust and soot accumulated in and around the fire before and after working on the fire. When replacing these articles we recommend that the replaced items are not broken up, but are sealed within a heavy duty polythene bag, clearly labelled as RCF waste. RCF waste is classed as a stable, non-reactive hazardous waste and may be disposed at a landfill licensed to accept such waste. Protective clothing is not required when handling these articles, but we recommend you follow the normal hygiene rules of not smoking, eating or drinking in the work area and always wash your hands before eating or drinking.**

**This appliance does not contain any component manufactured from asbestos or asbestos related products.**

# INSTALLER GUIDE

## 2. APPLIANCE DATA AND EFFICIENCY

### 2.1 General information.

Gas	Natural (G20)	Propane (G31) *
Inlet Pressure	20mbar	37mbar
Input - Max. (Gross)	6.0kW (20,500Btu/h)	6.1kW (20,800Btu/h)
Input - Min. (Gross)	1.7kW (5,800Btu/h)	3.2kW (10,918Btu/h)
Inlet Test Pressure (Cold)	20.0 ± 1.0mbar (8.0 ± 0.4in w.g.)	37.0 ± 1.0 mbar (14.85 ± 0.4in w.g.)
Gas Connection	8mm pipe	8mm pipe
Burner Injector	Cat 82 - 069	Size 128
Pilot & Atmosphere Sensing Device	Copreci Ref. O.D.S 21500/166	Copreci Ref. O.D.S 21500/166 Fitted with RBM 180 - 02 injector
Ignition	Piezo Electric. Integral with Gas Tap	Piezo Electric. Integral with Gas Tap
Aeration	See section 16.1	Non-adjustable

\* When converted using Kit 0595221

The appliance data label is located on a plate at the base of the fire. This can be seen by removing the lower trim.

### 2.2 Efficiency.

The efficiency of this appliance has been measured as specified in BS 7977 - 1 and the result is as below :

<b><u>Model</u></b>	<b><u>Efficiency % (Gross)</u></b>
752.	51
752 when converted to LPG.	52

The gross calorific value of the fuel has been used for this efficiency calculation. The test data from which it has been calculated has been certified by Advantica Certification services (0087). The efficiency value may be used in the UK Government's Standard Assessment Procedure (SAP) for energy rating of dwellings.

The conversion of **net** efficiency to **gross** was achieved by multiplying the net efficiency by the following conversion factor from Table E3 of SAP 2005, rounding down to the nearest whole number.



# INSTALLER GUIDE

Gas	Conversion factor from <b>net</b> to <b>gross</b> efficiency
Natural Gas	0.901
LPG	0.921

## 3. GENERAL INSTALLATION REQUIREMENTS

### 3.1 Regulations, Standards and Law.

The installation must be in accordance with these instructions.

For the user's protection, in the United Kingdom it is the law that all gas appliances are installed by competent persons in accordance with the current edition of the Gas Safety (Installation and Use) Regulations. Failure to install the appliance correctly could lead to prosecution. GAS SAFE REGISTER and CORGI require their members to work to recognised standards.

In the United Kingdom the installation must also be in accordance with:

All the relevant parts of local regulations.

All relevant codes of practice.

The relevant parts of the current editions of the following British Standards:-

BS EN 1856 Part 1 - Chimneys - Requirements for metal chimneys.

BS 715 - Specification for metal flue boxes for gas-fired appliances not exceeding 20kW.

BS EN 1858 - Chimneys - Components - Concrete flue blocks.

BS EN 1806 - Chimneys - Clay / ceramic flue blocks.

BS EN 1856 Part 1 - Chimneys - Requirements for metal chimneys.

BS 5440 Part 1 - Installation of flues.

BS 5440 Part 2 - Installation and maintenance of flues and ventilation for gas appliances of rated input not exceeding 70 kW net (1st, 2nd and 3rd family gases).

BS 6461 Part 1 - Masonry chimney & flues - Installation

BS 1251 - Fireplace components

BS 5871 Part 2 - Installation - Inset LFE gas fires

BS 6891 - Gas pipework installation

- In England and Wales, the current edition of the Building Regulations issued by the Department of the Environment and the Welsh Office.
- In Scotland, the current edition of the Building Standards (Scotland) Regulations issued by the Scottish Executive.
- In Northern Ireland, the current edition of the Building regulations (Northern Ireland) issued by the Department of the Environment for Northern Ireland.
- In the Republic of Ireland the installation must be carried out by a competent person and also conform to the relevant parts of:
  - a) The current edition of IS 813 "Domestic Gas Installations"
  - b) All relevant national and local rules in force.

# INSTALLER GUIDE

Where no specific instructions are given, reference should be made to the relevant British Standard Code of Practice.

## **3.2 Ventilation requirements.**

Normal adventitious ventilation is usually sufficient to satisfy the ventilation requirements of this appliance. In GB reference should be made to BS 5871 Part 2 and in IE reference should be made to the current edition of IS 813 “Domestic Gas Installations” which makes clear the conditions that must be met to demonstrate that sufficient ventilation is available.

## **3.3 The Atmosphere sensing device (ASD).**

The appliance is fitted with an A.S.D (Atmosphere sensing device). If the appliance closes down after a period of operation for no apparent reason, the consumer should be informed to stop using the appliance until the installation and appliance have been thoroughly checked. The A.S.D will shut the appliance down if an unacceptable amount of harmful products of combustion accumulate. Under no circumstances should the A.S.D be altered or bypassed in any way. Only a genuine manufacturer’s replacement part should be fitted. The individual A.S.D components are not replaceable.

## **3.4 Fireguard requirements.**

A fireguard complying with BS 8423 should be fitted for the protection of young children, the elderly, the infirm and pet animals.

## **3.5 Room considerations.**

**3.5.1** This appliance must not be installed in any room that contains a bath or shower or where steam is regularly present.

**3.5.2** An extractor fan may only be used in the same room as this appliance, or in any area from which ventilation for the appliance is taken, if it does not affect the safe performance of the appliance. Note the spillage test requirements detailed further on in this manual. If the fan is likely to affect the appliance, the appliance must not be installed unless the fan is permanently disconnected.

**3.5.3** Note that soft wall coverings (e.g. embossed vinyl, etc.) are easily affected by heat. They may scorch or become discoloured when close to a heating appliance. Please bear this in mind when installing.

## **3.6 Chimney preparation.**

**3.6.1** If the appliance is intended to be installed to a chimney that was previously used for solid fuel, the flue must be swept clean prior to installation. All flues should be inspected for soundness and freedom from blockages.

# INSTALLER GUIDE

**3.6.2** Any chimney damper or restrictor should be removed. If removal is not possible, they must be secured in the open position.

## **3.7 Fireplace preparation.**

**3.7.1** If the fireplace opening is an underfloor draught type, it must be sealed to stop any draughts.

**3.7.2** The fireplace floor should be reasonably flat to ensure that the convection box can be installed without it rocking and so that a good seal can be made at the bottom front of the box.

**3.7.3** The front face of the fireplace should be reasonably flat over the area covered by the convection box top and side flange seals to ensure good sealing. These faces should be made good if necessary.

**3.7.4** If the appliance is to be fitted against a wall with combustible cladding, the cladding must be removed from the area covered by the fascia. The cladding must also not touch the fascia (See figure 1). We suggest that the actual fascia is used as a template to mark the area for combustible cladding removal and that this area is increased by at least 2mm all round.

**3.7.5** If the fireplace opening is greater than the acceptable dimensions given in this guide, do not use the back of a fire surround or marble to reduce the opening. This may cause cracking of the surround back or marble.

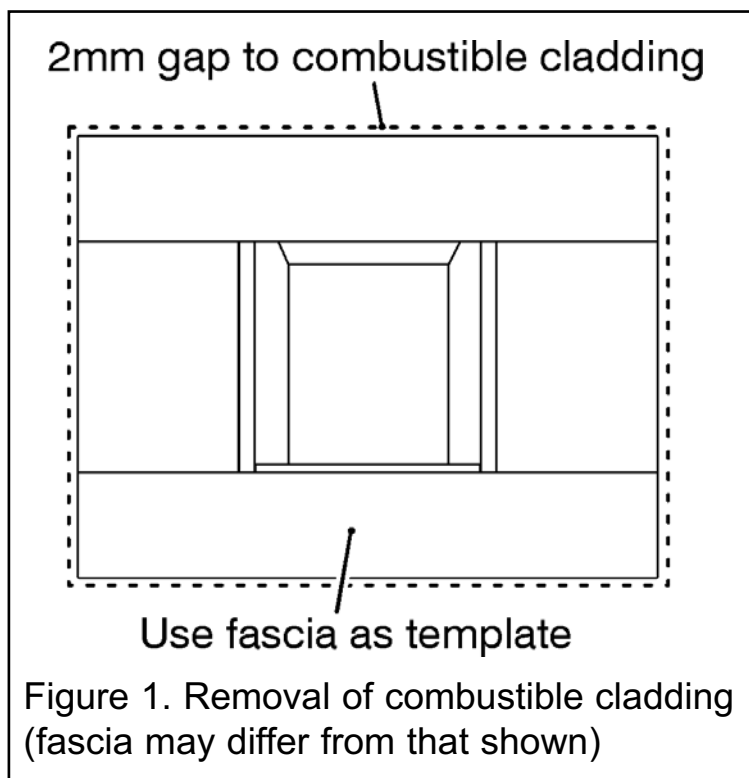

Figure 1. Removal of combustible cladding (fascia may differ from that shown)

## **3.8 The hearth.**

The appliance must be mounted behind a non-combustible hearth unless the conditions of section 3.10.1.1 are met (N.B. conglomerate marble hearths are considered as non-combustible). The appliance can be fitted to a purpose made proprietary class "O"-150°C surround. The hearth material must be at least 12mm thick. The periphery of the hearth (or fender) should be at least 50mm above floor level to discourage the placing of carpets or rugs over it.

The appliance must not stand on combustible materials or carpets (See figure 4).

# INSTALLER GUIDE

## 3.9 Fireplace clearances.

3.9.1 The minimum height from the base of the fireplace opening to the underside of any shelf made from wood or other combustible materials is detailed below:

- For a shelf up to 150mm deep: Minimum height = 750mm.
- For a shelf deeper than 150mm: 750mm + 12.5mm for every 25mm depth over 150mm (See figure 2).

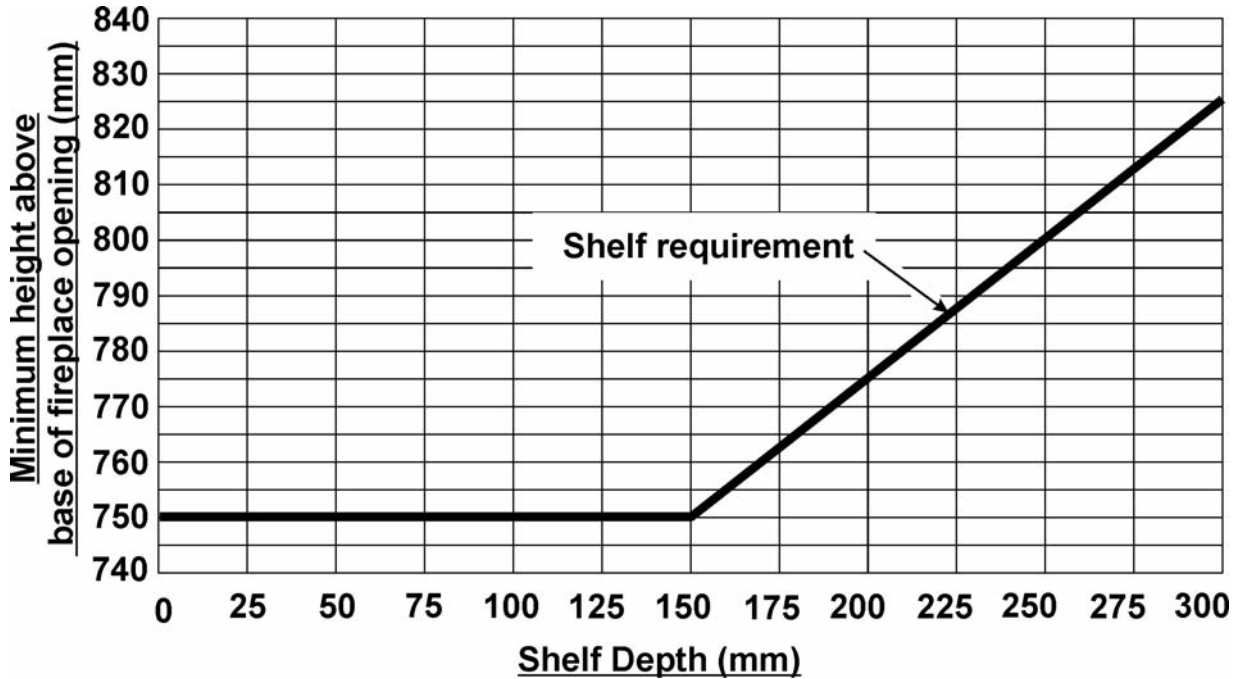
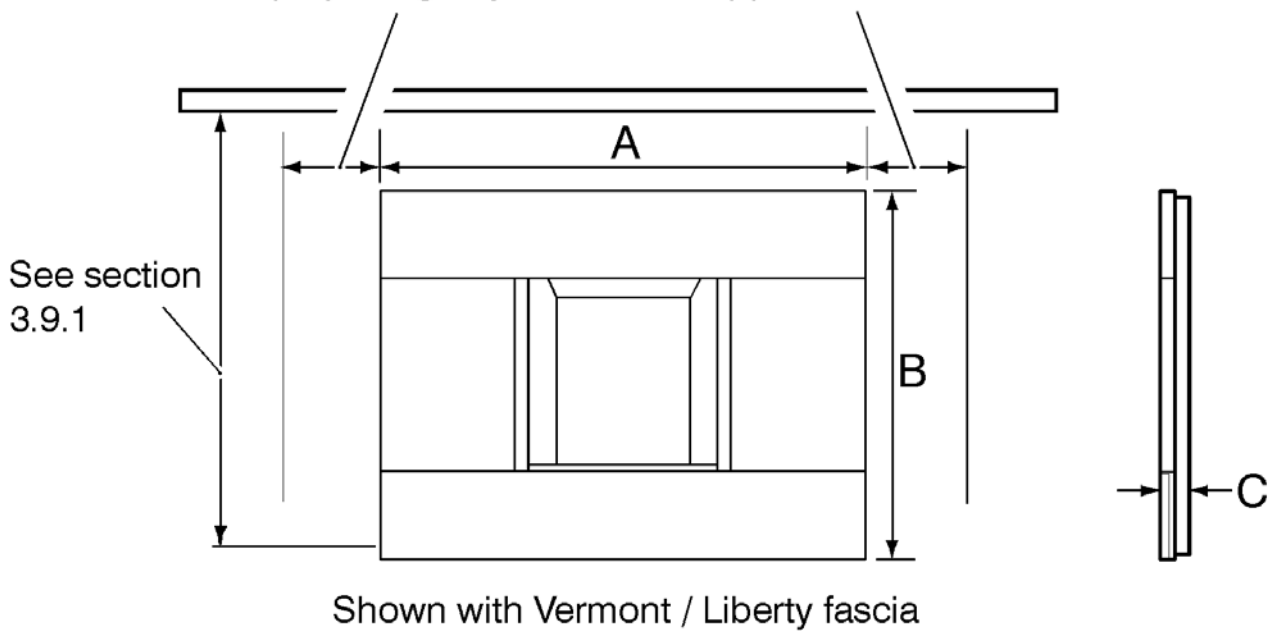

Figure 2. Combustible shelf clearances

3.18 The minimum allowable distance from the outside of the fascia to a corner wall having combustible material or any other combustible surface which projects beyond the front of the appliance is shown in figure 3.

# INSTALLER GUIDE

100mm minimum mandatory clearance to combustible and non-combustible surfaces projecting beyond front of appliance.



Model	Dimension A	Dimension B	Dimension C
Broadway	1020	626	50
Valor Landscape 2 Gas	1020	626	50
Vermont & Liberty	841	640	61

Figure 3. Appliance dimensions (Fascia may differ from that shown and is subject to manufacturing tolerances)

# INSTALLER GUIDE

## 3.10 Installation options.

In the United Kingdom, as supplied, the appliance can be installed in the following situations: -

### 3.10.1 Conventional fireplace and hearth.

To a fireplace complete with hearth as shown in figure 4. Chair brick removal may not be required providing at least 50mm clearance is available from the flue outlet to any fireplace component.

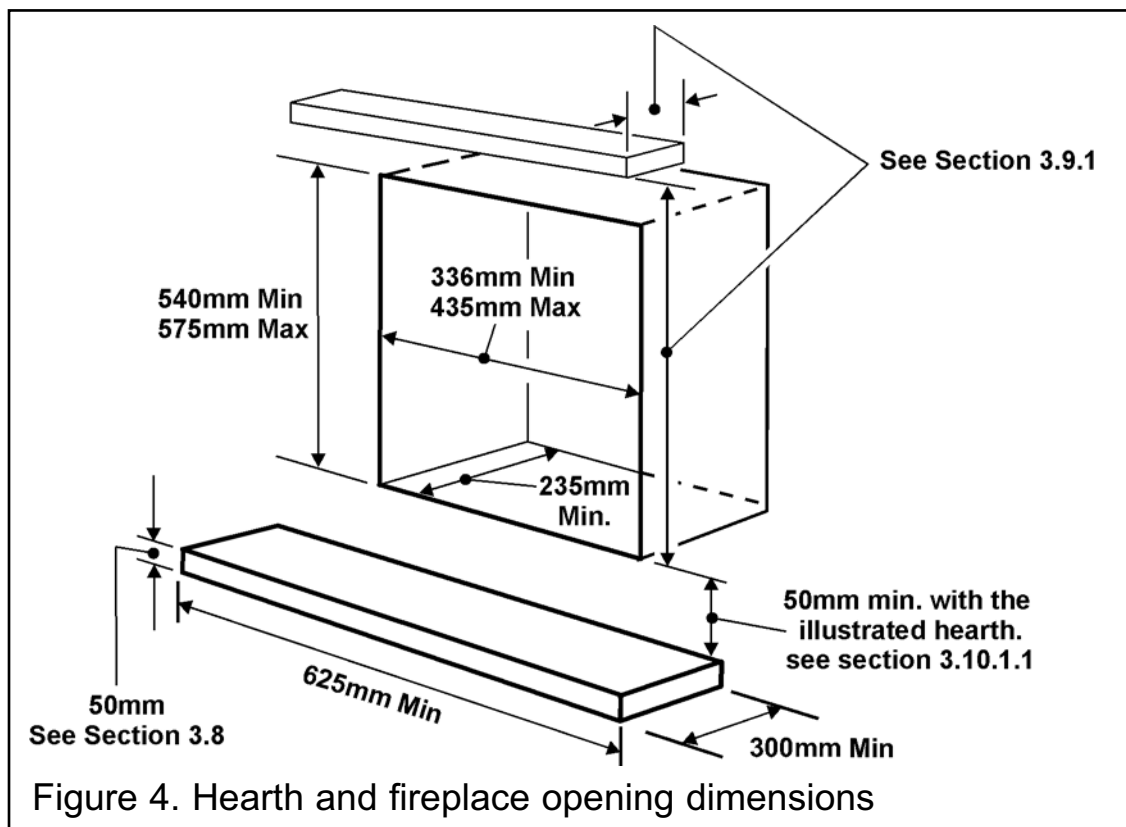

#### 3.10.1.1 'Hole-in-the-wall' Installations.

- It is recommended that a hearth should be installed as in section 3.8 (See figure 4).
- If no hearth is fitted, or a reduced depth hearth is fitted, the fire must be installed so that the distance from the base of the fireplace opening in the wall to the finished floor level is at least 72mm. Where there is no floor covering or carpet and the floor is of a type that is likely to be covered in such a way then the distance from the base of the fireplace opening in the wall to the finished floor level should be increased to at least 147mm.
- To protect from the risk of burns and ignition of clothing a tactile separator shall be used. The hearth detailed in section 3.8 meets the requirements for a tactile separator. If this is not used then a 625mm long fender, kerb, horizontal bar, or other barrier, being fixed not less than 50mm above floor level and positioned 300mm in front of the fixing plane of the fire will meet the requirement.

# INSTALLER GUIDE

## 3.10.2 Metal flue box and hearth.

The appliance can be installed to a fireplace incorporating a metal flue box complying with the constructional requirements of the current edition of BS 715 and with a flue conforming to BS EN 1856 part 1. The dimensions of the flue box must conform to those shown in figure 5.

The top surface of the metal flue box must be covered with a 50mm layer of mineral wool or equivalent insulation (See figure 5).

**Important Note:** Where the flue box has a base sheet that is single wall (i.e. a single metal sheet) the flue box must be mounted on a non-combustible hearth. The hearth material must be at least 12mm thick.

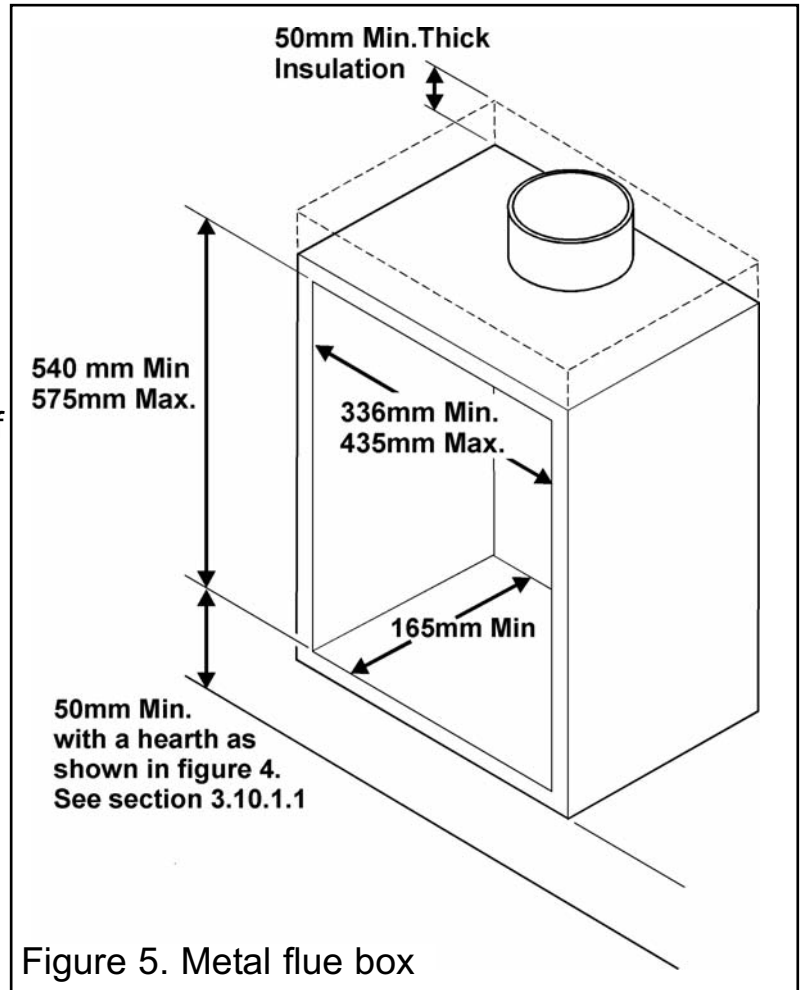

# INSTALLER GUIDE

## 3.10.3 Precast concrete or clay flue block system and hearth.

The appliance can be installed to a precast concrete or clay flue block system conforming to BS EN 1858 with dimensions as in figure 6.

BS 1289 part 1 recommends there should be an air space or insulation between the flue blocks and the plaster because heat transfer may cause cracking on directly plastered flues. However, generally this appliance is suitable for installations under all circumstances unless there is a history of cracking problems. Remember that faults such as cracking may be caused by poorly built and restrictive flues, e.g. mortar extrusions, too many bends, flue heights below three metres, restrictive terminations etc.

The appliance is suitable for installations conforming to older versions of BS1289 as well as the current edition. The flue blocks must have a minimum width not less than 63mm and a cross-sectional area not less than  $13,000\text{mm}^2$ . Older editions of BS1289 required a cross-sectional area of  $13,000\text{mm}^2$ . The current revision of the standard requires  $16,500\text{mm}^2$ . This appliance is suitable in both cases. The total depth of the opening measured from the finished front of the fireplace (Including plaster, surround etc.) must be as below:

If the width at the rear of the precast flue starter blocks is 300mm or greater the depth of the opening is to be not less than 138mm. Under these conditions the eyebolts will need to be located as close to the sides of the starter blocks as possible.

If the width at the rear of the precast flue starter blocks is less than 300mm then an additional 16mm of depth will be required to accommodate the eye bolts. Therefore if the starter blocks are less than 300mm wide the minimum depth of the opening will be not less than 154mm.

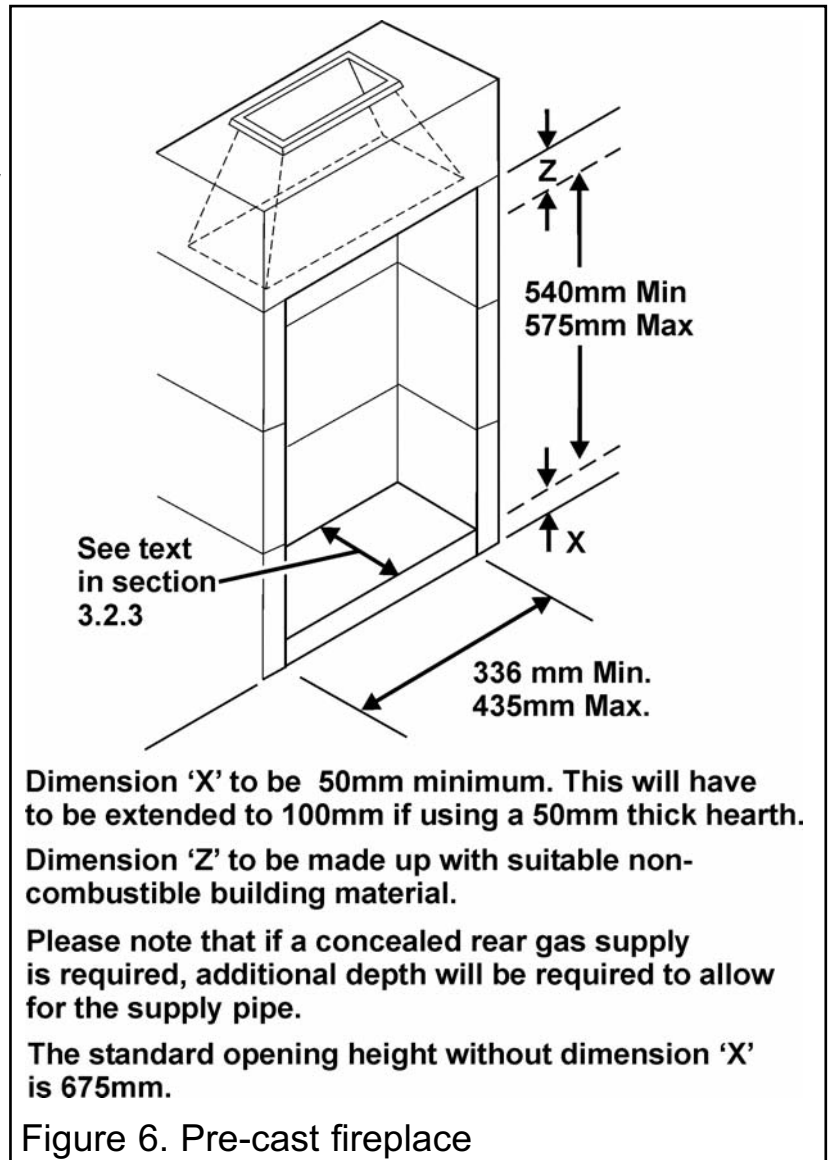



# INSTALLER GUIDE

## 3.11 Flues.

1. Suitable flues and minimum flue sizes are as follows:

*It should be noted that, as with many appliances, sharp bends or horizontal runs in metal flues at the top of the system can be a cause of problems in these types of installation.*

- 225mm x 225mm conventional brick flue.
- Single wall, twin wall or flexible flue liner with a minimum diameter of 125mm. The materials to be used are stainless steel or aluminium as specified in BS EN 1856 Part 1. The liner must be sealed to the surrounding area above the fireplace opening and to the top of the chimney. An approved terminal must be fitted.
- 175mm diameter lined brick or stone flue.
- 200mm diameter factory made insulated flue manufactured to BS4543 Part 2.
- 175mm diameter flue pipe. See BS6461 Part 1 for suitable materials.
- A properly constructed precast concrete or clay flue system conforming to BS1289 or BS EN 1858. This system is only suitable if the conditions stated in section 3.10.3 are met.

2. The flue must conform to BS 5440: Part 1 in design and installation.

The flue, measured from the bottom of the fireplace opening to the bottom of the terminal, shall be not less than 3m in actual vertical height. When calculated in accordance with BS 5440: Part 1 Annex A, the minimum **equivalent** height of the flue shall be 2.0m of 125mm dia. flue pipe.

3. The flue must not be used for any other appliance or application.

4. Proprietary terminals must comply with BS 715 or BS 1289. Any terminal or termination must be positioned in accordance with BS 5440 Part 1 to ensure that the products of combustion can be safely dispersed into the outside atmosphere. Where the appliance is connected to an unlined brick chimney it is generally unnecessary for the chimney pot to be replaced or for a terminal to be fitted unless the flue has a diameter smaller than 170mm.

5. The flue must be completely sealed so that combustion products do not come into contact with combustible materials outside the chimney.

## 3.12 Propane gas fires.

Propane gas appliances must not be installed in a room, which is built entirely below ground level (See BS 5871 Pt2).

# INSTALLER GUIDE

## 4. PACK CONTENTS

(See figure 7)

- 1 Hotbox and burner assembly
- 1 Fascia
- 1 Literature Pack (Not shown)
- 1 Burner tray trim
- 1 Loose parts pack including: -
- 1 Length of self-adhesive foam seal
- 2 Fire Retaining cables
- 2 Cable adjusters
- 1 Flue restrictor
- 2 No.8 x 3/8" tapping screws for securing the flue restrictor
- 2 M4 x 10 screws for securing the fascia
- 2 Eyebolts
- 2 Fibre / wooden plugs
- 1 Strip of floor sealing tape
- 1 Inlet "T" connector including pressure test point
- 1 Nut and olive for 8mm inlet pipe
- 1 Grommet for rear of hotbox.
- 1 Remote control handset
- 4 'AA' Batteries
- 1 'PP3' Battery
- 1 Ceramic fuel effect pack (Not shown)

Remove all the items carefully to prevent damage. Take special care when handling the ceramic components. Some items may be contained in the packaging fitments - Examine the packaging carefully before discarding. Check that all the items are present and undamaged.

# INSTALLER GUIDE

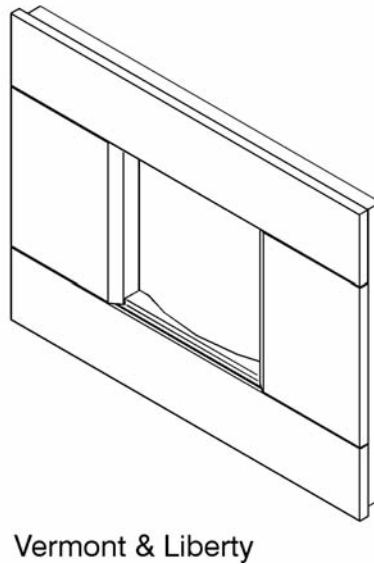
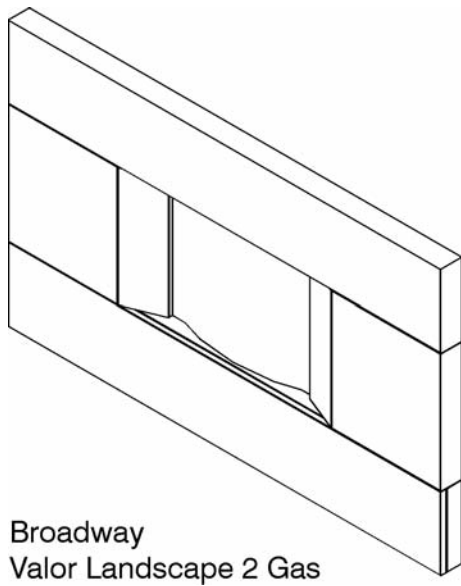
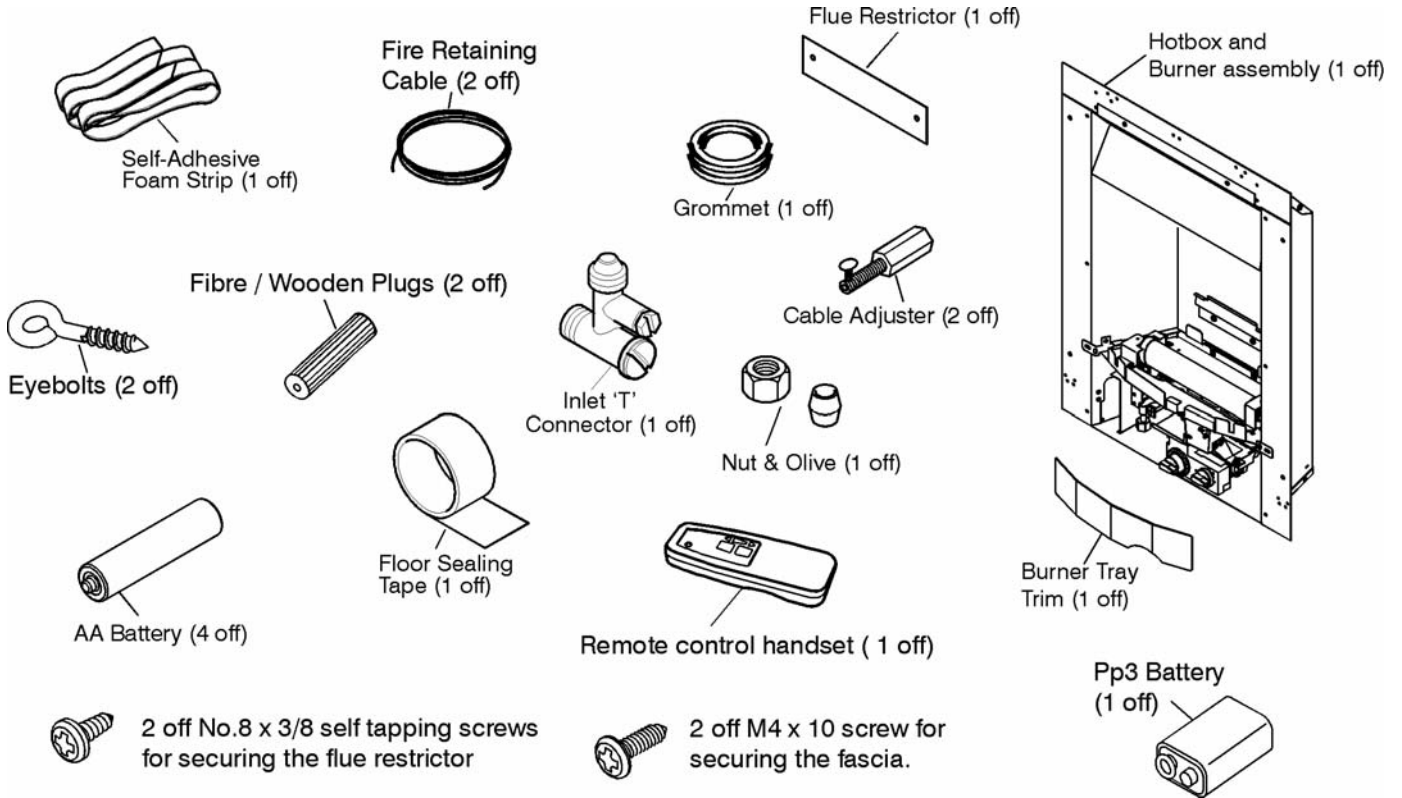

Figure 7. Pack contents

# INSTALLER GUIDE

## 5. FIREPLACE CHECK

### 5.1 Soundness for appliance attachment.

A primary method of retaining the appliance is provided: -

Using concealed tension cables fixed to the rear of the fireplace opening.

The method is detailed in section 9 of this manual. Make sure that the areas at the back of the fireplace are sound enough to take the eyebolts. If these areas have deteriorated due to prolonged use, they should be made sound with suitable cement.

### 5.2 Fireplace flue pull.

Close all doors and windows in the room in which the appliance is to be installed.

After confirming with a match that smoke is drawn into the flue, light a 13 gram smoke pellet and check that there is a definite flow through the flue. Verify outside that the smoke exits from one terminal only and that the termination is suitable.

Observe where possible, upstairs rooms and loft spaces for signs of escaping smoke indicating a defective flue. If there is not a definite flow warm the flue for a few minutes and repeat the smoke pellet test. If there is still no definite flow the flue may need remedial work – **Do not fit the appliance until there is a definite flow through the flue.**

## 6. IGNITION CHECK

Before attempting to install, it is worth checking that the ignition system performs satisfactorily.

Set the right hand control knob to the ● 'OFF' position.

● Push in the right hand control knob and turn anticlockwise through the ignition position marked

★ and up to the pilot position marked ● . A

spark should flash across from the electrode pin to the pilot tip. If there is no spark, check that the spark gap is as shown in figure 8. If there is no spark check the following: -

- Ensure that the electrode lead is connected to the terminal at the base of the electrode.
- If the above is correct, check for damage to the electrode lead.

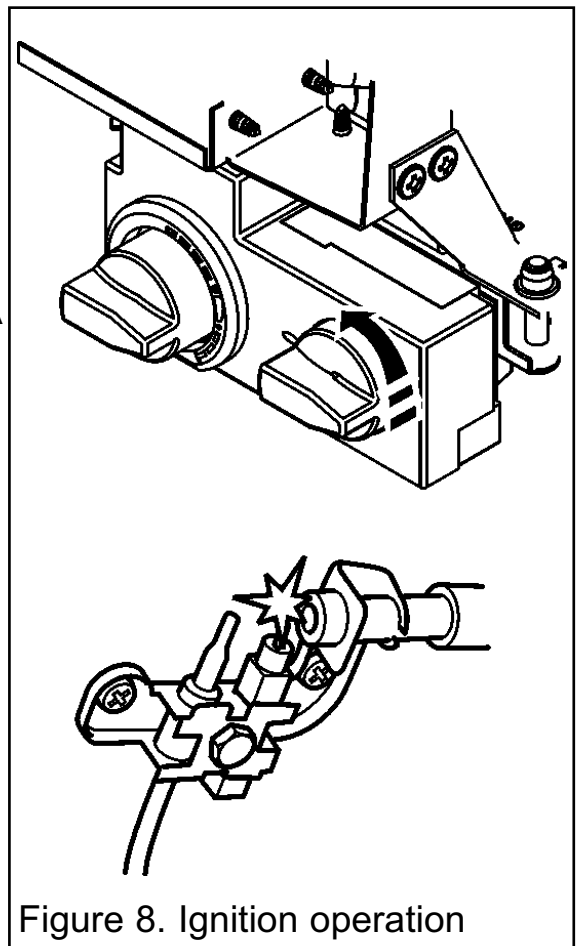

Figure 8. Ignition operation

# INSTALLER GUIDE

## 7. GAS SUPPLY CONNECTION

A nut and olive are provided for an 8mm pipe inlet connection to the inlet 'T' connector at the bottom front of the appliance. The inlet 'T' connector can be rotated to allow a connection from any direction. The inlet 'T' connector includes a valve for isolating the gas supply and a pressure test point.

The supply pipe must be rigid material. Flexible pipe must not be used.

### Concealed Supply Pipe Connection.

If a concealed connection from inside the fireplace is required then, **before the appliance is fitted into the fireplace** it will be necessary to extend the supply line so that it will project through the hole in the back of the hotbox and run to the inlet 'T' connector at the front. The pipe run from the supply line up to the rear opening in the hotbox must be kept away from the area which will be taken by the hotbox when it is installed. Note that the centre of the appliance inlet 'T' connector is 25mm above the fireplace floor. The inlet 'T' connector should be fitted to the supply pipe at this stage.

## 8. PREPARING APPLIANCE FOR INSTALLATION

### 8.1 Appliance preparation.

1. Remove any transit tape and packing and inspect for any evidence of mishandling which might affect the performance. Each unit is flame tested before it leaves the factory and as a result there may be slight discolouration around the burner ports.
2. The remote control receiver box at the right hand side of the hotbox base is held in place with hook and loop material tape. Hold the top of the receiver box and pull forward to remove.
3. Detach the burner unit from the hotbox by removing two screws (See figure 9). Lift the burner unit clear.

### IMPORTANT

**Before continuing with the installation of this gas fire the aeration setting on the burner must be checked. The aeration is factory set for use with a ceramic pebble fuel effect (See section 16.1)**

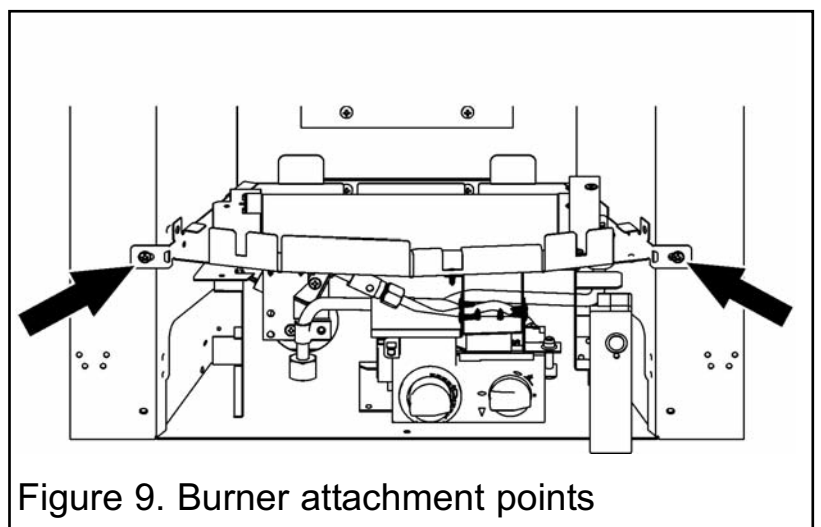

Figure 9. Burner attachment points

4. It is important that the grommet supplied in the loose parts pack is fitted to the hole in the rear of the hotbox.

# INSTALLER GUIDE

## 8.2 Fitting the foam seal.

There is a length of self adhesive foam seal supplied with the fire. This will need to be fitted to the outer rear edges of the side and top flanges of the hotbox. Cut the foam seal to the required length. Be careful not to stretch the seal when measuring. Remove the protective backing from the foam seal and fit this to the rear of the hotbox flange (See figure 10).

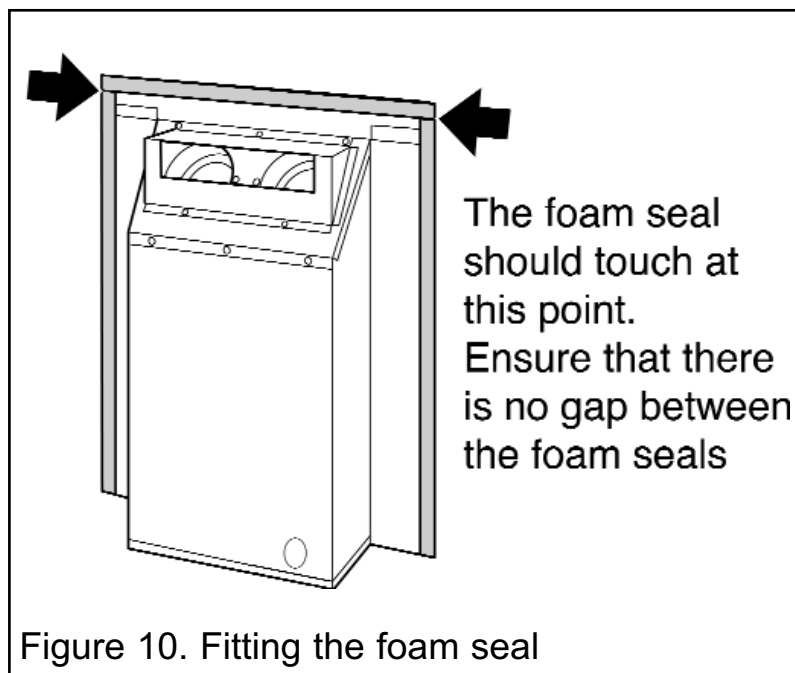

## 8.3 The flue restrictor.

This appliance is supplied with a flue restrictor for use where the flue draught is excessive. **The restrictor must not be fitted where a precast flue or a 125mm flue liner is used.** For flue liners greater than 125mm and all other installations the restrictor should be fitted. There may however, be certain exceptional circumstances where fitting the restrictor causes the fire to fail the spillage test. In such cases the restrictor will have to be removed. After removal conduct the spillage check again.

Fit the restrictor as shown in figure 11 using the two No.8 x 3/8" screws provided.

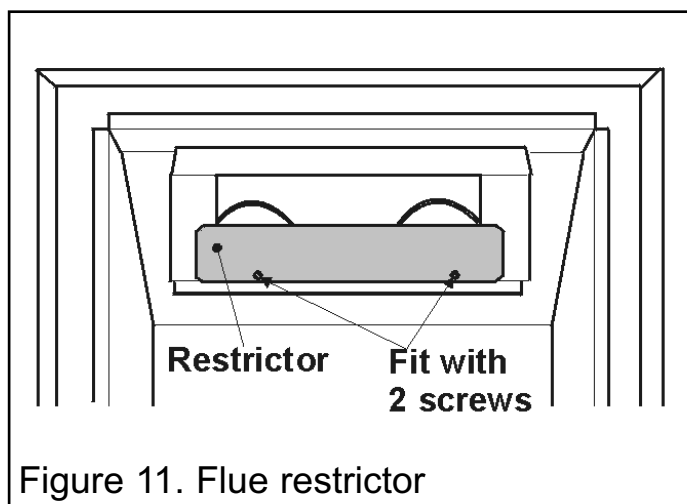

# INSTALLER GUIDE

## 9. HOTBOX INSTALLATION

### 9.1 Hotbox installation.

1. Make sure that the relevant areas at the fireplace back are sound enough to take the eyebolts. If these areas have deteriorated due to prolonged use they should be made sound with suitable cement.

2. Drill two holes in the rear wall of the fireplace for the wall plugs. The holes should be drilled within the range of positions shown in figure 12 using a suitably sized masonry drill for the wall plugs supplied. The holes should be equidistant each side of the centre line of the fireplace to ensure that the appliance finishes centrally in the opening when tension is applied to the cables.

3. Insert a fibre / wooden plug into each hole. Use the fibre / wooden plugs supplied with this appliance - **Never use plastic plugs instead of the fibre / wooden plugs supplied.** Screw the eyebolts into the plugs. Make sure that the eyebolts are secure.

4. Place the hotbox unit close to the fireplace but allow sufficient access into the fireplace opening so that the cables can be threaded through the eyebolts and returned through the back of the hotbox. If a concealed connection is being used, insert the hotbox into the fireplace feeding the supply pipe through the pierced hole in the rear grommet.

5. The rear of the hotbox has a flue opening. Locate one end of the cable through the small round hole to the side of the flue opening and up into the adjacent slot. Give the cables a pull so that they grip (See figure 13).

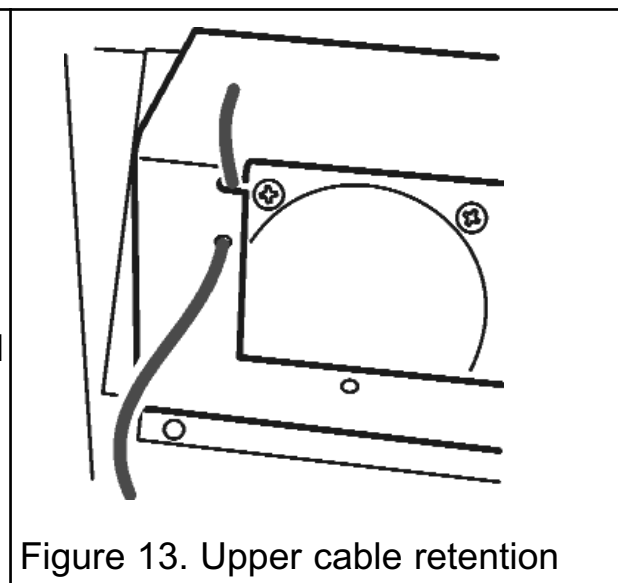
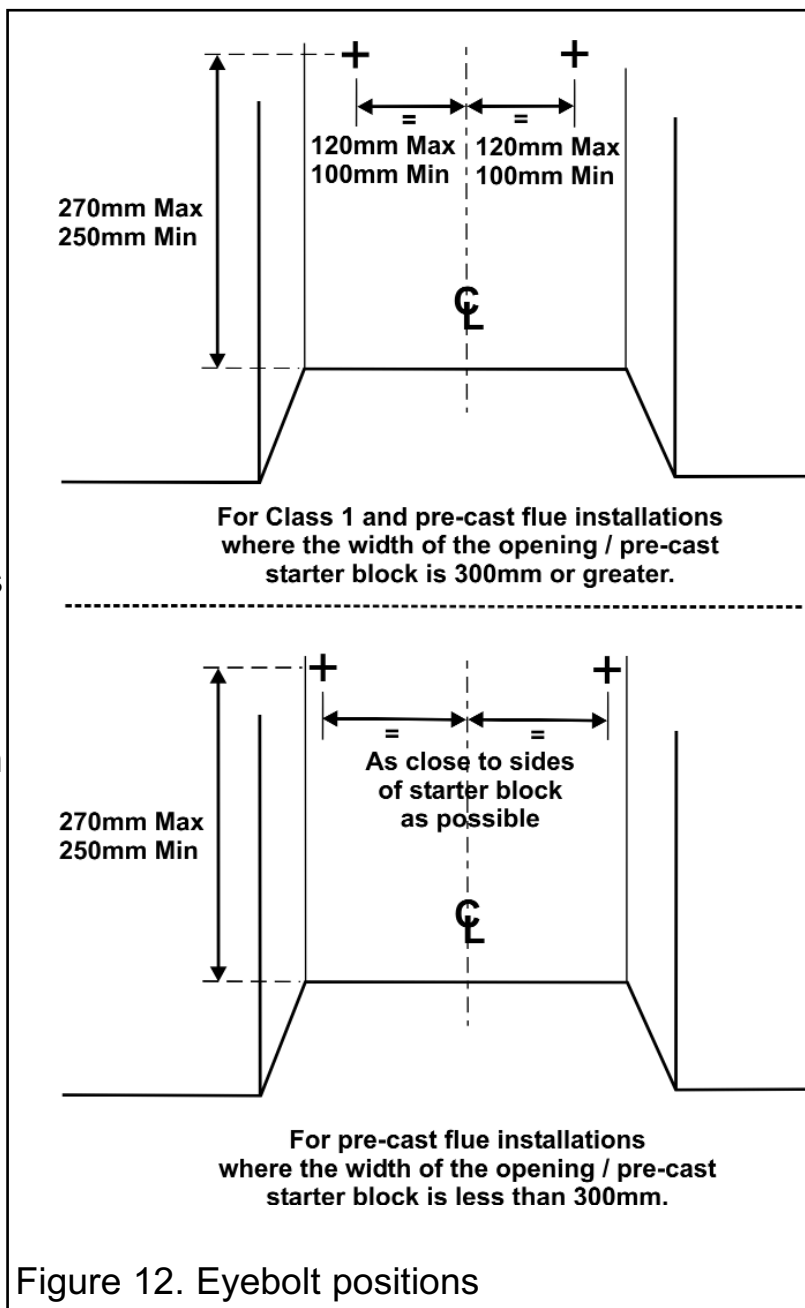

# INSTALLER GUIDE

6. Thread the cables through the eyebolts. Return the cables through the holes near the bottom of the hotbox side panels (See figure 14).

7. Place the hotbox fully back into the fireplace opening so that it is sealed against the fireplace front surround.

8. Fit a cable retainer over the bottom end of each cable.

9. Pull each cable taut. Push the cable retainers hard up against the back panel. The end of the cable adjuster will pass into the hole. Tighten the screws in the retainers so that they clamp the cables in position. Apply tension to the cables by turning the hexagonal adjusters by hand. (See figure 15).

10. Inspect the installation of the hotbox against the fireplace surround. If the hotbox is aligned squarely and the sealing is satisfactory, fully tighten the cable retainers.

11. If the hotbox is not correctly aligned, release the tension on the cables by slackening the screws and turning the hexagonal adjusters fully anticlockwise. The hotbox should then automatically realign itself. Pull each cable taut again and push the cable retainers back against the back panel. Again, tighten the screws in the retainers and apply tension to the cables by turning the hexagonal adjusters clockwise as far as possible.

12. Do not cut off any excess cable, instead coil up the cable so that they are available to allow easy removal and refitting of the appliance during subsequent service calls.

## 9.2 Floor sealing (All Installations).

Using the floor sealing tape supplied, seal the bottom of the hotbox to the fireplace and hearth floor. Run the tape round the front edge of the wall. We recommend that the tape go no further than 8mm down the front face of the wall as it may be visible under the base of the fascia. This will depend on the height of the installation (See figure 16).

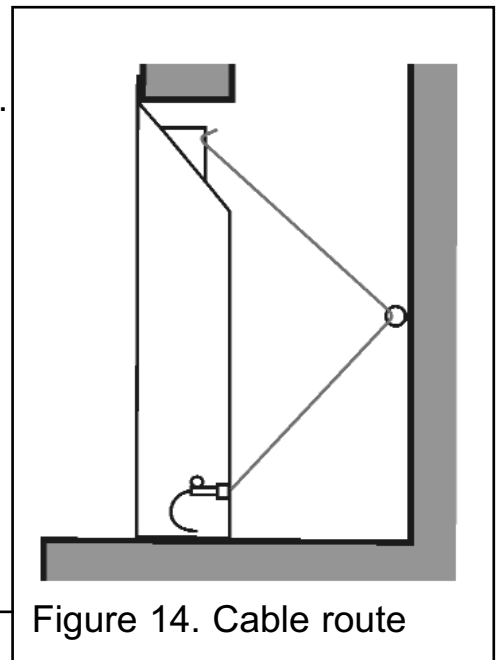

Figure 14. Cable route

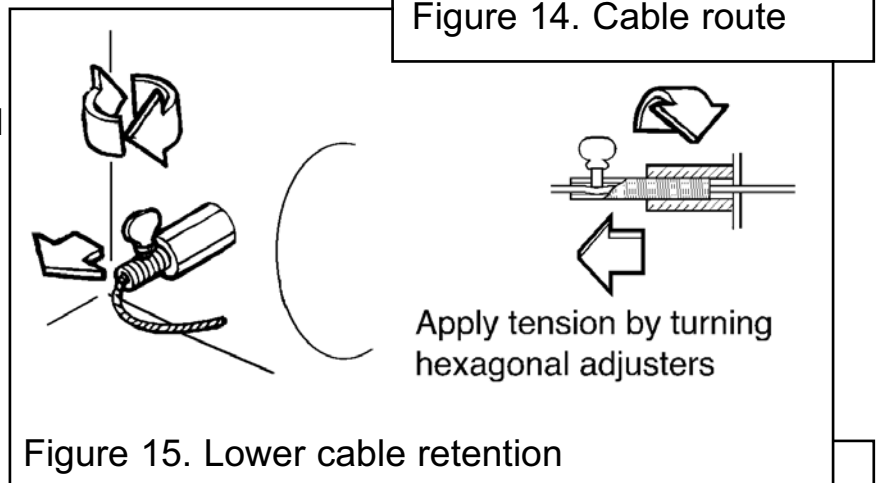

Figure 15. Lower cable retention

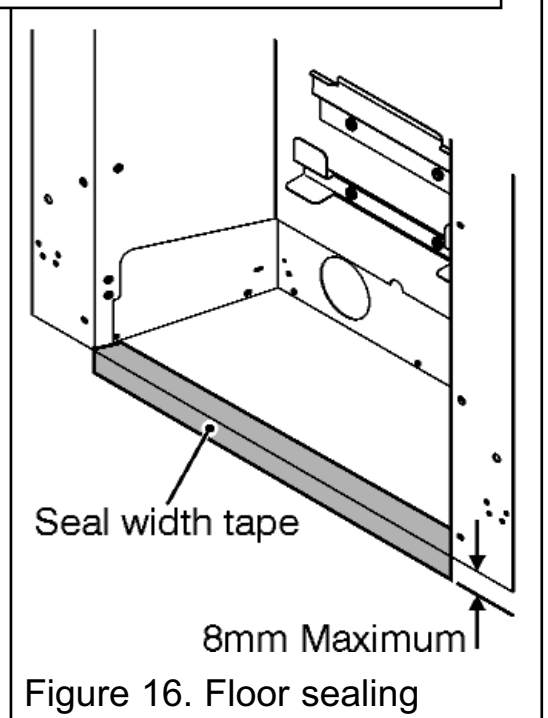

Figure 16. Floor sealing



# INSTALLER GUIDE

## 10. BURNER INSTALLATION

### 10.1 Burner and supply pipe installation.

1. Refit the burner unit to the hotbox using the two screws removed previously.
2. Connect the supply line to the appliance.
3. If closed, open the isolating valve at the inlet 'T' connector.
4. Turn on the gas supply and pressure check the installation pipework for gas soundness. In the United Kingdom check in accordance with the current edition of BS 6891. In the Republic of Ireland refer to the current edition of I.S. 813 "Domestic gas installations".

### 10.2 Fitting the batteries.

1. Remove the receiver battery cover and fit the four 'AA' batteries as indicated inside the receiver base. Replace the receiver battery cover. Place the receiver back into place. The ultra-sonic sensor must face towards the front of the appliance.
2. Fit the PP3 battery to in the remote control handset. To do this slide the battery cover back.

### 10.3 Preliminary burner checks.

Some burner operations can be checked at this stage. Checking now will mean that less disassembly will be required if any problems are found. **A full check should still be made, however, after final installation.**

### 10.4 Lighting the pilot.

Please note:- The fire must be lit manually.

1. Ensure that the pilot burner control knob is in the OFF position (1 in figure 17).
2. Depress the pilot burner control knob and turn anti-clockwise to the ignition position (2 in figure 17) to activate the piezo ignition system. A 'click' will be heard and the pilot should light. If the pilot does not light immediately, repeat the above procedure, keeping the knob depressed for several seconds in order to purge any air from the system. If after ten seconds, ignition has not occurred, turn the

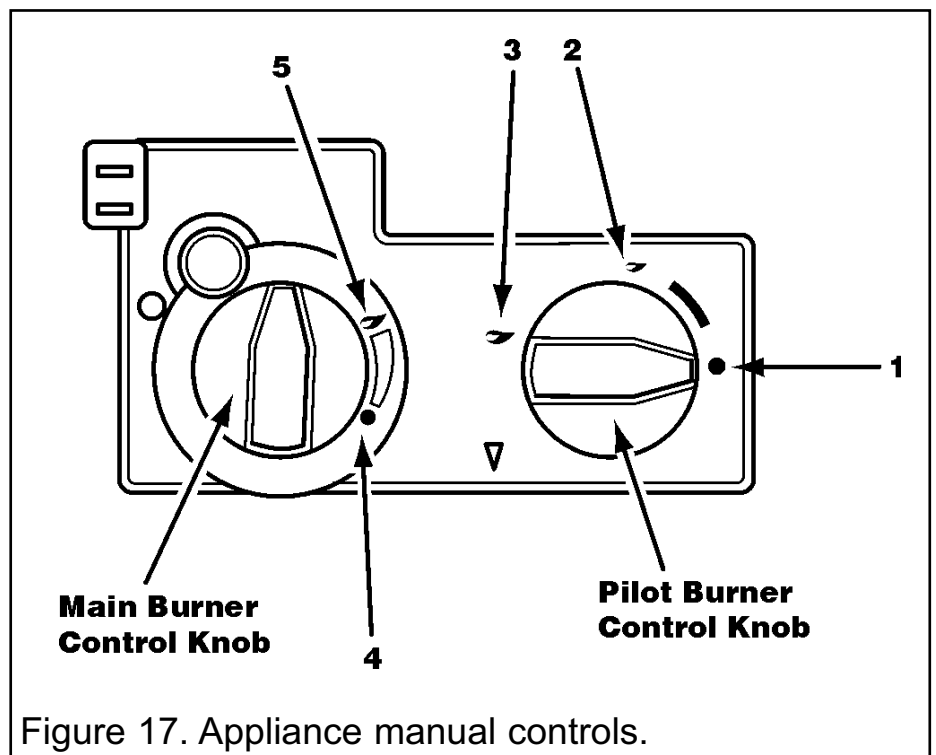

Figure 17. Appliance manual controls.

# INSTALLER GUIDE

control knob back to the OFF position. Wait 30 seconds and then repeat the ignition procedure.

**3.** When the pilot is alight keep the knob depressed for ten seconds to allow the pilot flame to stabilise.

**4.** Release the knob. When the knob is released, the pilot should remain alight. If the pilot fails to remain alight, repeat the ignition procedure, this time keeping the knob depressed for a longer period of time.

## 10.5 Checking the heat settings.

**1.** Once the pilot light is established, light the main burner by turning the pilot burner control knob anti-clockwise to the "main burner on" position (3 in figure 17), and by then turning the main burner control knob to the high position (5 in figure 17).

**2.** Check the full range of heat settings by turning the main burner control knob slowly between the high position and the low position (4 in figure 17).

## 10.6 To turn the fire back to pilot setting.

Turn the main burner control knob fully clockwise. Alternatively turn the pilot burner control knob clockwise to the ignition position (2). Refer to figure 17.

## 10.7 To turn the fire off.

Rotate the pilot/burner control knob clockwise to position 1, as shown in figure 17.

## 10.8 Using the remote control handset.

**1.** Keep the pilot burner at the "main burner on" position. Check the full range of main burner heat settings using the remote control handset. In order to vary the flame effect between High and Low positions, press, and keep depressed, either the High button, or the Low button as appropriate (See figure 18).

The handset operates on ultrasonic principles, and as such it is not necessary to point it directly at the fire.

**2.** Use the handset to switch to the pilot only setting by depressing the Low button until only the pilot flame remains alight.

**3.** In order to disable the handset, but still leave the pilot alight, turn the pilot burner control knob to the ignition position (2 in figure 17).

**4.** Turn the fire off by rotating the pilot burner control knob to the OFF position (1 in figure 17).

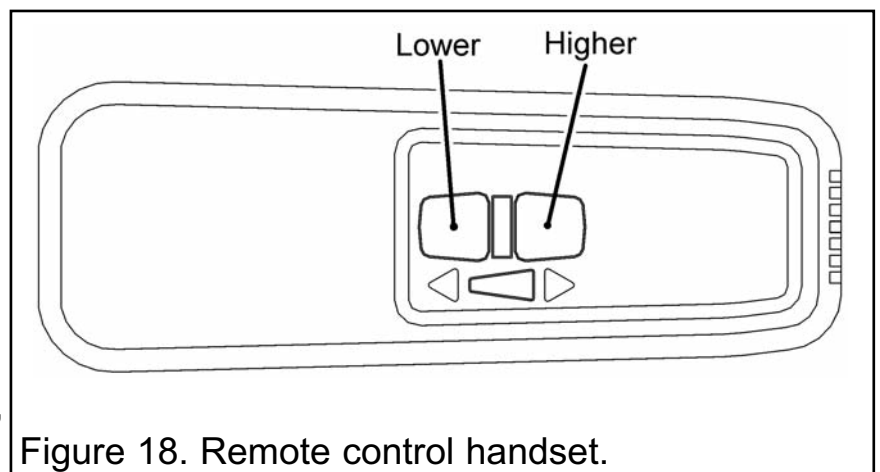

Figure 18. Remote control handset.

# INSTALLER GUIDE

## 10.9 Inlet pressure check.

The appliance is pre-set to give the correct heat input at the inlet pressure shown in section 2 of this guide. No adjustment is necessary.

1. Check the inlet pressure by fitting a pressure gauge at the test point. The test point is on the inlet 'T' connector (See figure 19). Check the pressure with the appliance alight and set at maximum output.
2. After checking, turn off the appliance. Remove the pressure gauge and replace the test point sealing screw.
3. Relight the appliance. Turn to the maximum output position and test around the sealing screw for gas soundness with a suitable leak detection fluid.

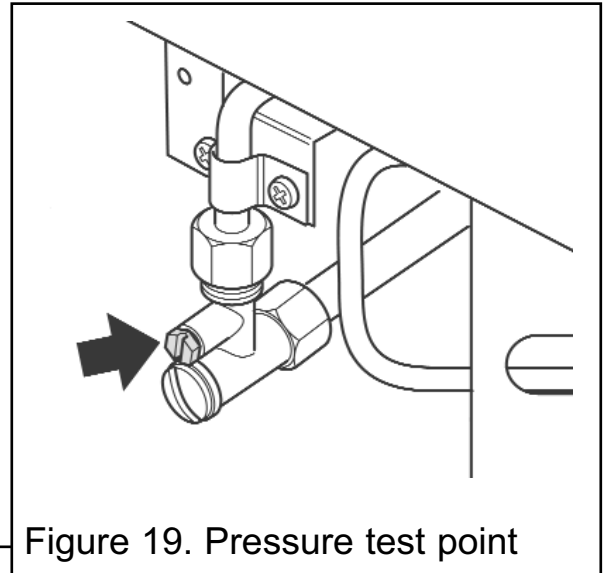

Figure 19. Pressure test point

## 10.10 Fitting the burner tray trim.

1. Fit the burner tray trim over the front rim of the burner tray. Push the trim fully down (See figure 20).

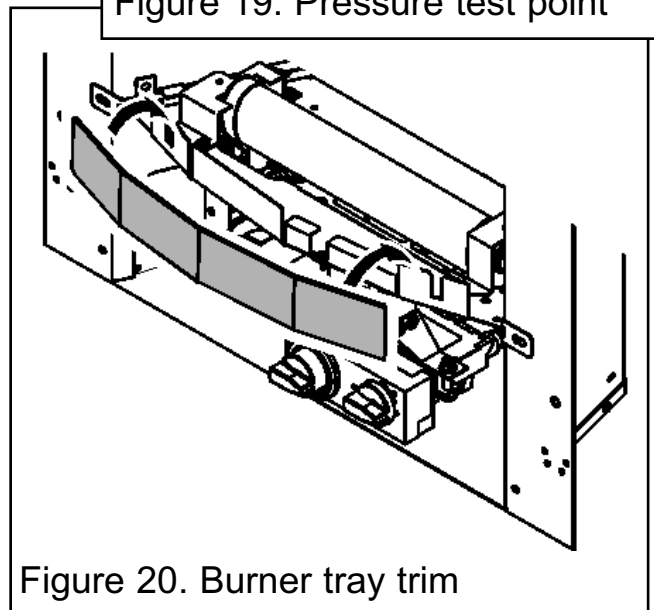

Figure 20. Burner tray trim

# 11. FITTING THE CERAMIC FUEL EFFECT

The installer and owner guide for the ceramic fuel effect is supplied with the ceramic fuel effect. It is important that the fitting guide for the ceramic fuel effect be placed inside or attached to this guide and handed to the customer following completion of the 'Final review' section.

# INSTALLER GUIDE

## 12. FASCIA INSTALLATION

### 12.1 Fitting the fascia.

1. Remove the fascia from its pack and remove any protective covering.
2. The lower front cover on the fascia is held in place with strong magnets. Remove the lower front cover. To do this, support the main body of the fascia and pull gently on the outer edges of the cover. Place the cover in a safe place away from the work area.
3. Carefully lift the fascia. Place the fascia against the fireplace front surface so that the retaining plate at the back of the fascia is directly above the two upper retaining brackets at the top of the hotbox. Lower the fascia unit making sure that the retaining plate locates fully into the brackets on the hotbox (See figure 21).
4. Secure the bottom of the fascia using the two M4 x 10 screws supplied (See figure 22).

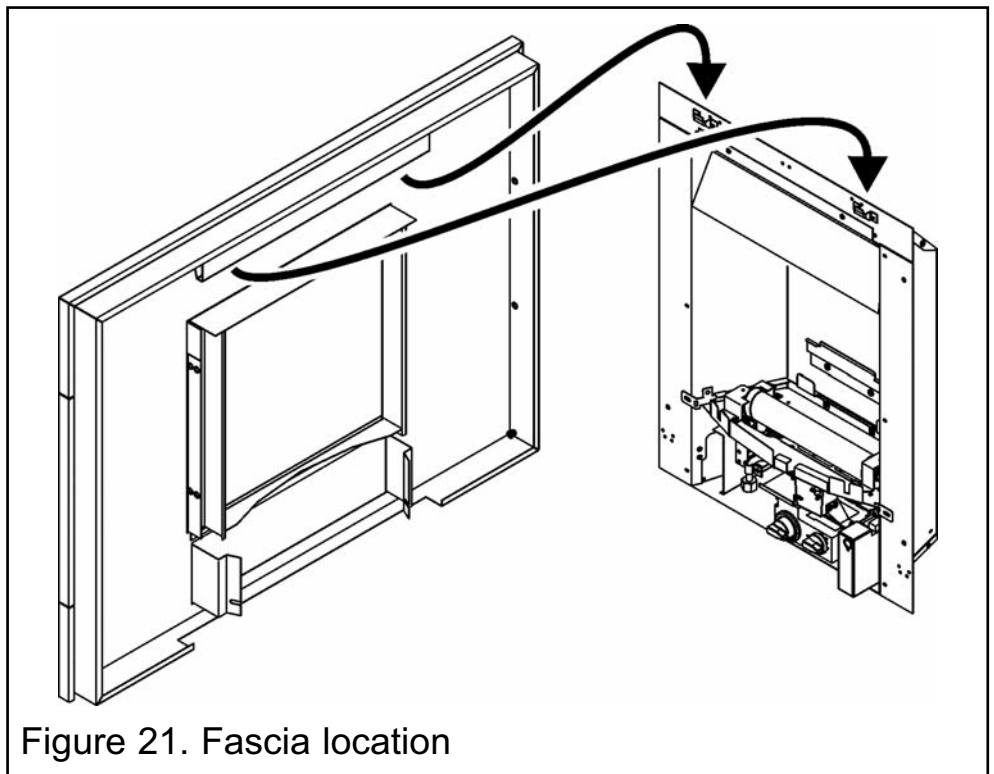

Figure 21. Fascia location

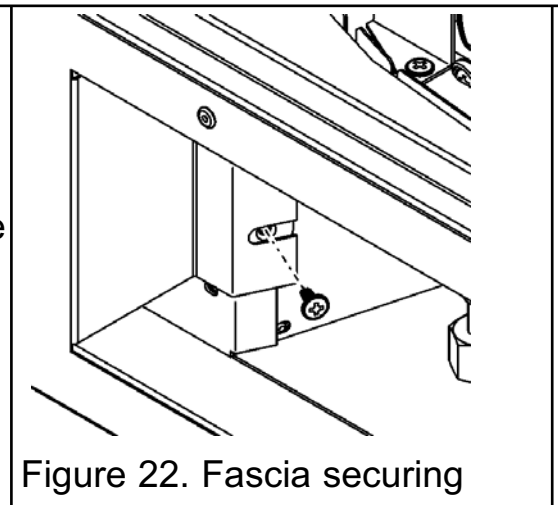

Figure 22. Fascia securing

## 13. FULL OPERATING CHECKS

### 13.1 Check the operation of the remote control.

With the ceramic fuel effect in position the control operation must now be fully rechecked as in sections 10.4 to 10.8. Make sure that the isolating valve at the inlet 'T' connector is open.

*When operating the fire for the first time, some vapours may be given off which could set off smoke alarms in the vicinity. These vapours are quite normal with new appliances. They are totally harmless and will disappear after a few hours use.*

*This fire may be controlled manually, by use of the controls mounted on the appliance. The flame settings may also be controlled by means of the remote control handset.*

# INSTALLER GUIDE

## 14. SPILLAGE & FLAME SUPERVISION CHECKS

### 14.1 Check for spillage.

**A spillage check must be made before leaving the installed appliance with the customer. Make this with all the ceramic fuel effect pieces and fascia in position.**

1. Close all doors and windows in the room containing the appliance.
2. Light the appliance and set to the maximum heat setting.
3. Leave the appliance on for five minutes.
4. Place the smoke match into the appliance canopy (See figure 23).
5. The installation is satisfactory if the smoke is drawn into the appliance. If the smoke is not drawn into the appliance, leave the appliance alight at the maximum setting for a further ten minutes and then repeat the test. If smoke is still not drawn into the appliance, inspect the sealing to the fireplace surround. If the sealing is satisfactory but the appliance is installed with the flue restrictor (See section 8.3), remove the restrictor, reseal the appliance and retest. If smoke is still not drawn into the appliance, **disconnect the appliance and seek expert advice.**

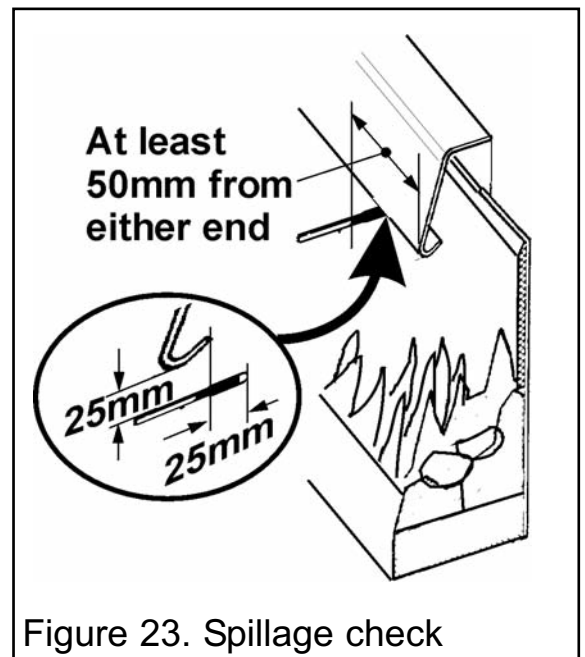

6. If the above test is satisfactory, open all internal connecting doors, hatches, etc., in the room. Keep all doors and windows that open to the outside of the building closed. Recheck for spillage as above. If an extractor fan is installed in the same room as the appliance or a connecting room, check that spillage does not occur with the fan operating and all doors and other openings between the fan and the appliance open. If the smoke is drawn into the appliance, continue with the installation. If the test is not satisfactory, **disconnect the appliance and advise the customer of the cause of failure.**

### 14.2 Flame supervision and spillage monitoring system.

The pilot unit incorporates a system that will automatically shut off the gas supply if the pilot flame goes out or if there is insufficient oxygen due to spillage or lack of ventilation.

Check that the system operates properly as follows;

- Light the appliance. Set at the maximum heat setting and leave for one minute.
- Turn back to "OFF" to extinguish the pilot. **Note the time when the pilot goes out.** Listen for a snap sound at the gas tap. **Note the time when the sound is heard.** This sound is caused by an electromagnetic valve shutting off the gas supply

# INSTALLER GUIDE

through the tap. The valve is located in the body of the tap. The valve should operate **within 60 seconds of the pilot going out**. If the valve does not operate within this time limit do not allow the appliance to be used until the fault has been corrected. **This monitoring system must not be adjusted, bypassed or put out of operation.**

**This monitoring system, or any of its parts, must only be exchanged using Valor Fires authorised parts.**

## 15. FINAL REVIEW

**1. COMPLETE THE INFORMATION IN THE WARRANTY AND SERVICE SECTION OF THE OWNER GUIDE (See last pages of this guide).**

**2.** Visually inspect the appliance. Clean off any marks incurred during installation.

**3.** Advise the customer how to operate the fire.

**4.** Explain to the customer that the appliance has a flame failure and spillage monitoring system. Point out the explanation of this system shown in the owner guide. Advise that if the fire goes out for any reason, wait at least three minutes before relighting. Stress that if the monitoring system repeatedly shuts off the fire, the appliance should be switched off and a specialist should be consulted. Point out that the lighting instruction details are on a metal plate attached at the bottom of the appliance.

**5.** Advise that the fire may give off a slight odour while new. This is quite normal and it will disappear after a short period of use.

**6.** Advise that any cleaning must only be carried out when the fire is off and cold.

**7.** Advise the customer that they should read the owner guide before operating the fire and always follow the advice in the section headed "Cleaning your fire".

**8.** Advise the customer that the appliance will operate to its maximum potential if the flue is primed during the first 20 – 30 minutes of use. To do this, simply turn the control to its highest setting. This will also burn off any carbon deposits that may have formed during previous use.

If using the appliance for long periods it is beneficial to change between settings. This will also help to remove any carbon deposits that may form during use.

**9.** Recommend that the appliance should be serviced and the chimney inspected by a competent person at least annually.

If the appliance is in premises in the United Kingdom occupied by a tenant, point out that by law a landlord must have any gas appliance, flue and pipework which is situated in a tenant's premises checked for safety at least every 12 months.

**10.** Advise the customer that the fascia, hotbox and ceramic pieces can be cleaned as described in the owner guide and that the ceramic fuel effect pieces must be replaced as described in those instructions.

*Stress that no extra ceramic fuel effect pieces must be added over and above those supplied with the appliance and that any replacements must only be the authorised spares. Warn that ignoring this advice could cause incomplete clearance of the products of combustion with consequent health hazards.*

# INSTALLER GUIDE

11. Inform the customer that the serial number for the appliance is located on the information label located behind the lower front fascia trim and underneath the burner.
12. Hand the literature pack with this guide to the customer.

## 16. SERVICING & PARTS REPLACEMENT

Always turn off the gas supply before commencing any servicing (The appliance inlet “T” connector incorporates an isolating valve).

It is recommended that, at least once a year, the appliance is disconnected and the fireplace opening checked and cleared of any debris.

This product uses fuel effect pieces and a burner compartment rear wall containing Refractory Ceramic Fibres (RCF), which are man-made vitreous silicate fibres. Excessive exposure to these materials may cause irritation to eyes, skin and respiratory tract. Consequently, it is important to take care when handling these articles to ensure that the release of dust is kept to a minimum. To ensure that the release of fibres from these RCF articles is kept to a minimum, during installation and servicing we recommend that you use a HEPA filtered vacuum to remove any dust and soot accumulated in and around the fire before and after working on the fire. When replacing these articles we recommend that the replaced items are not broken up, but are sealed within a heavy duty polythene bag, clearly labelled as RCF waste. RCF waste is classed as a stable, non-reactive hazardous waste and may be disposed at a landfill licensed to accept such waste. Protective clothing is not required when handling these articles, but we recommend you follow the normal hygiene rules of not smoking, eating or drinking in the work area and always wash your hands before eating or drinking.

This appliance does not contain any component manufactured from asbestos or asbestos related products.

- Check that the appliance is clean and that soot or debris is not blocking the gaps between the ceramic fuel effect pieces causing an imperfect flame.
- Check that soot or debris is not impairing the electrode spark or pilot burner.
- Check that soot or debris is not blocking any of the slots in the main burner.
- After servicing, make sure that the ceramic rear wall and the ceramic fuel effect pieces are replaced correctly as described in the installer and owner guide supplied with the ceramic fuel effect. The ceramic fuel effect guide may have been placed inside or attached to this guide.
- Always test for gas soundness and spillage after servicing the appliance.

# INSTALLER GUIDE

## 16.1 Checking the aeration setting of the burner.

1. The aeration shutter is factory set for use with a 'pebble' ceramic fuel effect. It is important to ensure that the aeration shutter setting is correct for the ceramic fuel effect used. Check the aeration shutter setting even if fitting the 'pebble' fuel effect (See figure 24).

2. To adjust the aeration setting to suit the fuel effect used, loosen the two shutter screws, slide the aeration shutter to the desired position and tighten the fixing screws.

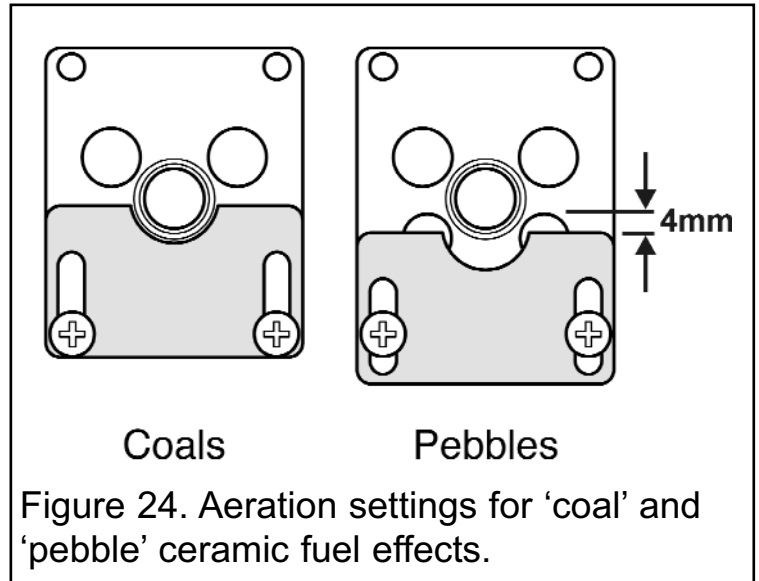

## 16.2 To remove the complete burner unit.

1. Remove the lower fascia trim. This is held in place with strong magnets. Hold the outer edges and pull away from the fascia.

2. Remove the two fascia securing screws (See figure 25).

3. Remove the fascia. To do this, hold the fascia sides, gently pull the base of the fascia forward and lift clear of the upper retaining brackets.

4. Remove the ceramic fuel effect.

5. Support the inlet 'T' connector to avoid straining the pipework and disconnect the appliance from the inlet 'T' connector.

6. The remote control receiver box at the right hand side of the hotbox base is held in place with hook and loop material tape. Hold the top of the receiver box and pull forward to remove.

7. Detach the burner unit from the hotbox by removing two screws (See figure 26).

8. Replace in the reverse order.

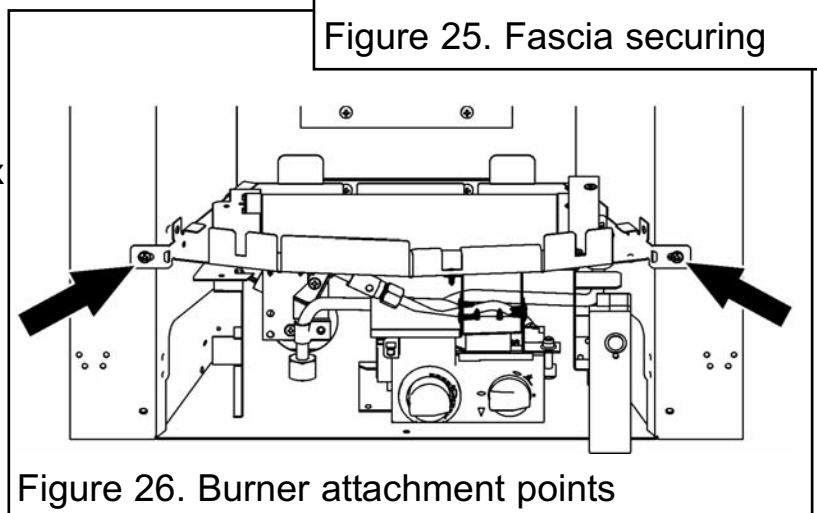
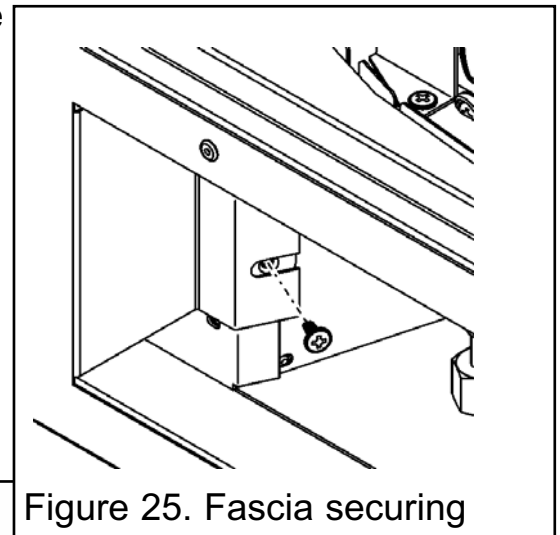



# INSTALLER GUIDE

## 16.3 To remove the pilot unit.

1. Remove the burner unit (See section 6.2).
2. Remove the burner tray trim.
3. Unscrew and remove the two screws from the gas valve shield (See figure 27). Place the shield to one side.
4. Detach the pilot pipe from the pilot unit.
5. Detach the thermocouple from the gas valve.
6. Detach the electrode lead from the underside of the electrode tab. Do this by holding the lead as close to the electrode as possible. This will limit the possibility of damaging the lead connection.
7. Remove the two screws securing the pilot unit (See figure 28).
8. Refit in the reverse order.

*Note: The pilot unit is an atmosphere sensing device. It must be replaced as a whole assembly. Its individual components are not separately replaceable.*

## 16.4 To remove the gas valve.

(See figure 29).

1. Remove the complete burner module as in section 16.2.
2. Remove the electrode lead at the pilot. Do this by holding the lead as close to the electrode as possible. This will limit the possibility of damaging the lead connection.
3. Unscrew the thermocouple at the rear of the gas valve.
4. Remove the two motor lead connectors from the front of the valve.
5. Undo the inlet, outlet and pilot nuts on the gas valve (See figure 29).
6. Remove the two mounting screws on the underside of the gas valve (See figure 29).
7. Remove the valve by sliding it forward.
8. Replace in reverse order. The motor lead connectors are two different sizes. They will only fit to the correct motor terminals.

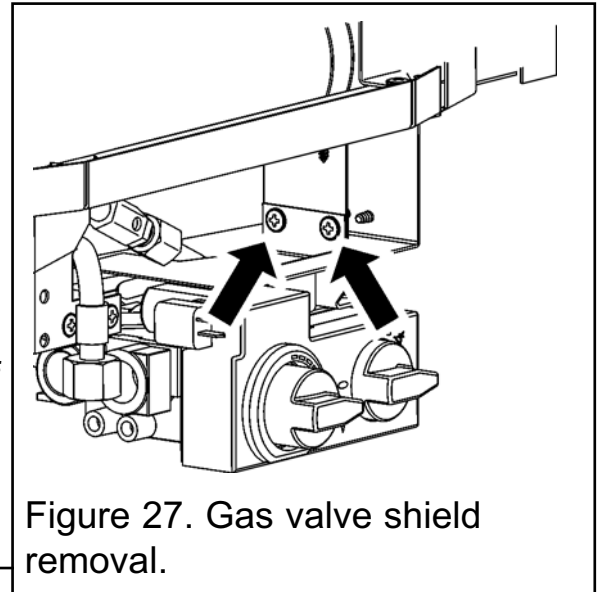

Figure 27. Gas valve shield removal.

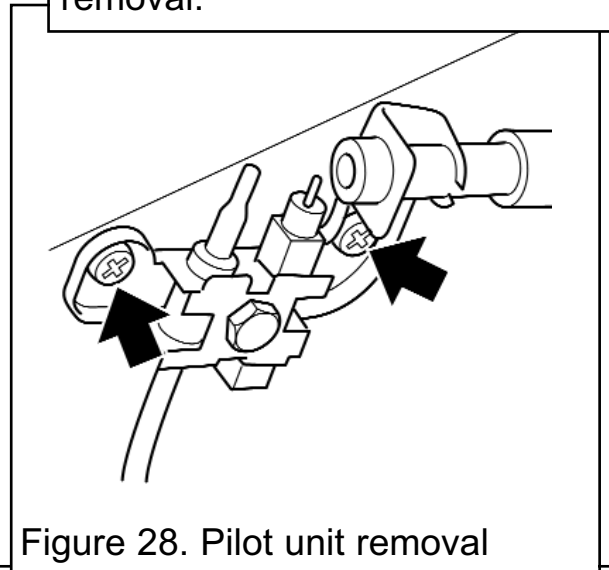

Figure 28. Pilot unit removal

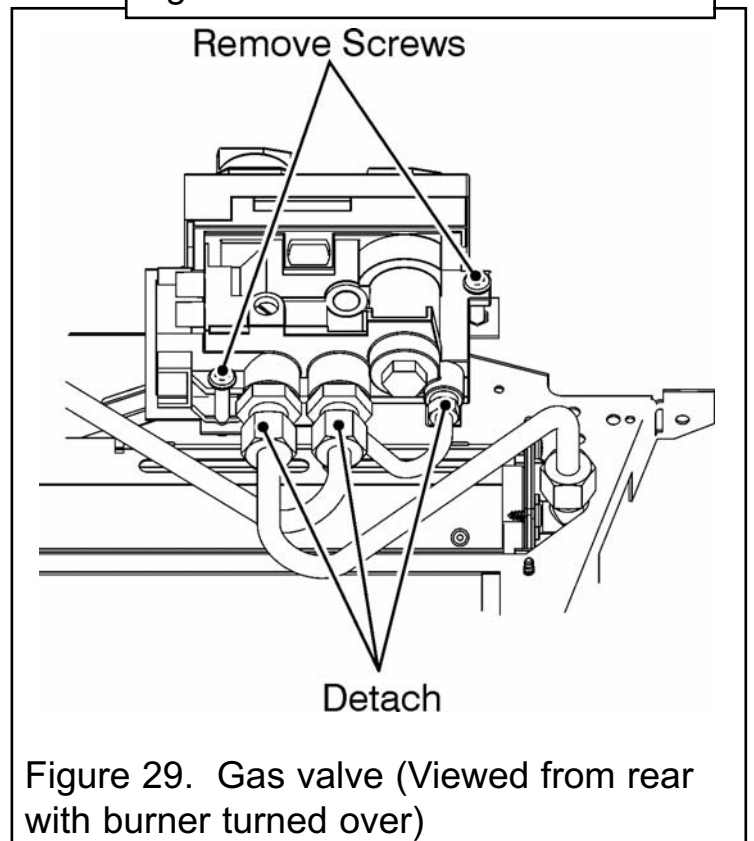

Figure 29. Gas valve (Viewed from rear with burner turned over)

# INSTALLER GUIDE

## 16.5 To replace the burner.

1. Remove the burner unit (See section 16.2).
2. Support the elbow injector and unscrew the injector nut.
3. Remove the two screws from the burner clamping plate (See figure 30)
4. Lift the right hand side of the burner, slide it to the right and lift clear
5. Refit in reverse order.

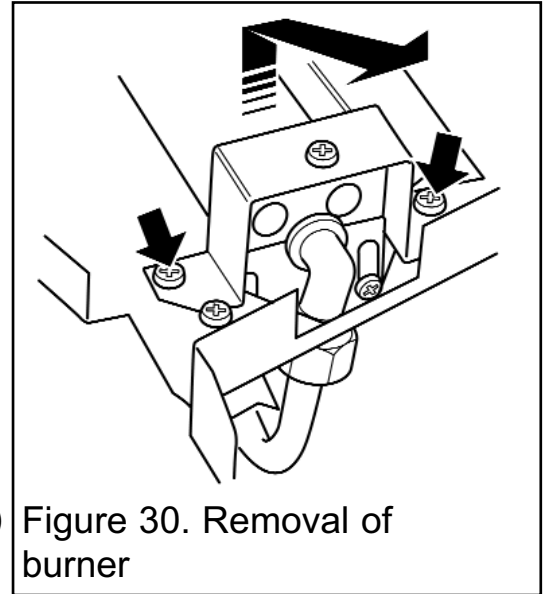

Figure 30. Removal of burner

## 16.6 To remove the main burner injector.

1. Remove the burner (See section 16.5).
2. Remove the burner clamping screw (See figure 31)
3. Unscrew the injector from the burner
4. Refit in the reverse order.

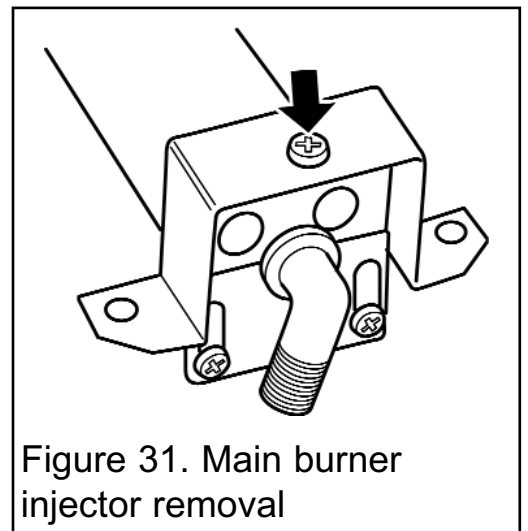

Figure 31. Main burner injector removal

## 16.7 To remove the appliance from the fireplace.

1. Remove the burner unit - See section 16.2.
2. Slacken the hexagonal adjusters on the cable retainers and unscrew the thumb screw to release the cables.
3. Refit as described in section 9. Make sure gas soundness, sealing, spillage test and performance are satisfactory.

# OWNER GUIDE

FOR WARRANTY AND SERVICE INFORMATION  
SEE PAGES 44 TO 47

# OWNER GUIDE

## LIST OF CONTENTS

<u>Section</u>	<u>Page</u>
<b>SAFETY</b>	<b>37</b>
<b>GAS CONSUMPTION</b>	<b>38</b>
<b>APPLIANCE DIMENSIONS</b>	<b>39</b>
<b>OPERATING YOUR FIRE</b>	<b>40</b>
The Oxysafe flame sensing & flue blockage safety system.	40
Lighting the pilot.	40
Heat settings.	41
To turn the fire back to pilot setting.	41
To turn the fire off.	41
Using the remote control handset.	41
<b>CLEANING YOUR FIRE</b>	<b>42</b>
Metal parts.	42
Ceramic fuel effect and rear wall.	42
Burner.	42
<b>CERAMIC FUEL EFFECT REFITTING</b>	<b>43</b>
<b>MAINTENANCE</b>	<b>43</b>
Regular maintenance.	43
Replacement ceramics.	43
<b>WARRANTY AND SERVICE</b>	<b>44</b>

---

This gas fire is designed to meet the most stringent quality, performance and safety requirements to provide you with many years' trouble-free service.

This guide aims to improve your understanding and appreciation of your gas fire by providing simple and informative instructions to ensure that you benefit from the excellent performance and features it has to offer.

# OWNER GUIDE

## SAFETY

### IF YOU SMELL GAS

- **DON'T SMOKE.**
- **EXTINGUISH ALL NAKED FLAMES.**
- **DON'T TURN ELECTRICAL SWITCHES ON OR OFF.**
- **TURN OFF THE GAS SUPPLY AT THE METER OR TANK AS APPROPRIATE.**
- **OPEN DOORS AND WINDOWS TO GET RID OF THE GAS.**
- **IMMEDIATELY CALL THE GAS EMERGENCY SERVICE FROM A NEIGHBOURS PHONE - SEE YOUR LOCAL TELEPHONE DIRECTORY.**

**Do** have the fire installed by a competent person. In the United Kingdom, installation must be in accordance with the latest edition of the Gas Safety (installation & use) Regulations. In the Republic of Ireland, installation must be in accordance with all national and local regulations in force.

**Do** have the chimney swept prior to installation if it was previously used for solid fuel.

**Do** have the fire installed in accordance with the installation instructions.

**Do** provide a minimum clearance of 750mm from the base of the fireplace opening to any shelf made of wood or other combustible material where the shelf is not more than 150mm deep. For a shelf deeper than 150mm, add 12.5mm to the clearance for every 25mm of additional shelf depth (See figure1).

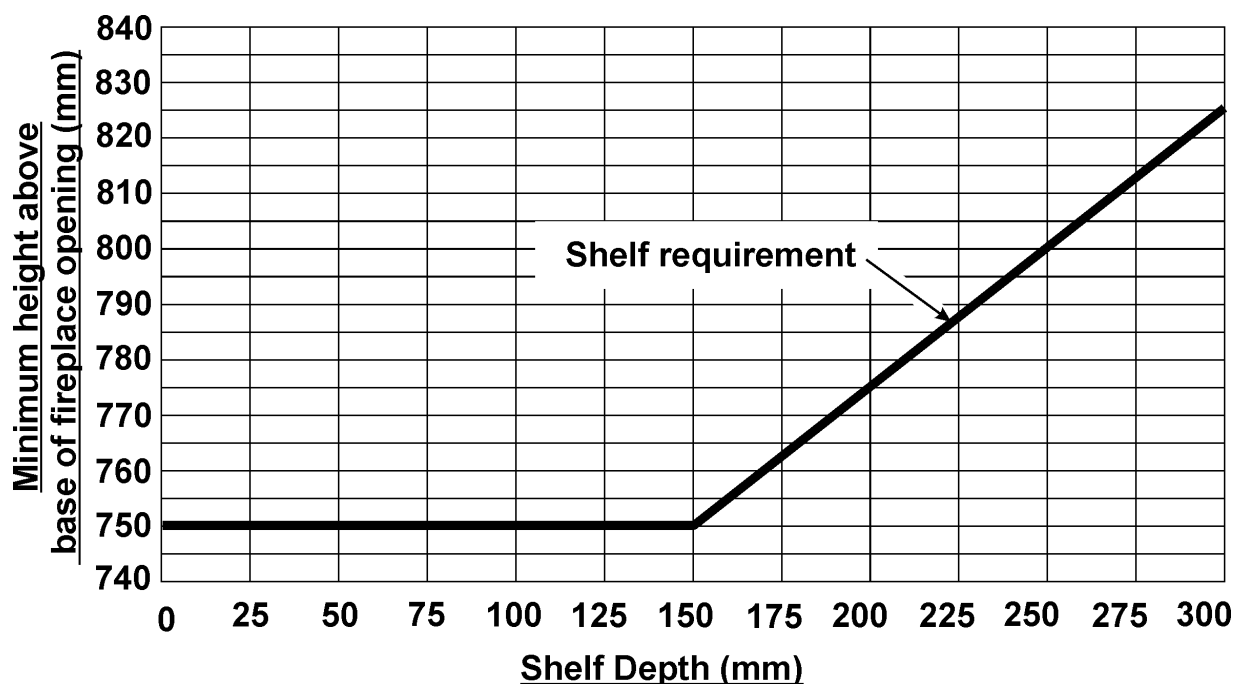

Figure 1. Combustible shelf clearances

**Do** always use a fireguard complying with BS 8423 for the protection of young children, the elderly, the infirm or pet animals.

**Do** wait three minutes before attempting to relight if the fire is switched off or the flames are extinguished for any reason. (Your fire is fitted with a safety device that will automatically shut off the gas supply to the fire, if for any reason, the flame goes out)

# OWNER GUIDE

**Do** get advice about the suitability of any wall covering near your fire. Soft wall coverings (e.g. embossed vinyl, etc.) which have a raised pattern are easily affected by heat. They may, therefore, scorch or become discoloured when close to a heating appliance. Please bear this in mind whenever you are considering redecorating.

**Do** provide a minimum side clearance as detailed in figure 2. Please bear this in mind if ever you are altering the room.

---

**Don't** hang clothing, towels or any other fabrics over the fire.

**Don't** put more ceramic fuel effect pieces on the fire than the number given in this guide or use any ceramic fuel effect pieces other than those authorised for this fire. Incorrect combustion could result.

**Don't** put paper or other materials onto your fire.

**Don't** use the fire with damaged base ceramics.

**Don't** place any combustible material (rugs, carpet, plastic tiles, etc.) on the hearth

**Don't** attempt to clean or service the fire until it has been switched off and allowed to cool completely.

## GAS CONSUMPTION

### Model 752

Has a maximum natural gas input of 6.0kW (Gross)

Has a maximum natural gas output of 3.0kW

Has a minimum natural gas input of 1.7kW (Gross)

Has a minimum natural gas output of 0.87kW

### Model 752 when converted using kit number 0595221

Has a maximum propane gas input of 6.1kW (Gross)

Has a maximum propane gas output of 3.17kW

Has a minimum propane gas input of 3.2kW (Gross)

Has a minimum propane gas output of 1.664kW

# OWNER GUIDE

## APPLIANCE DIMENSIONS

100mm minimum mandatory clearance to combustible and non-combustible surfaces projecting beyond front of appliance.

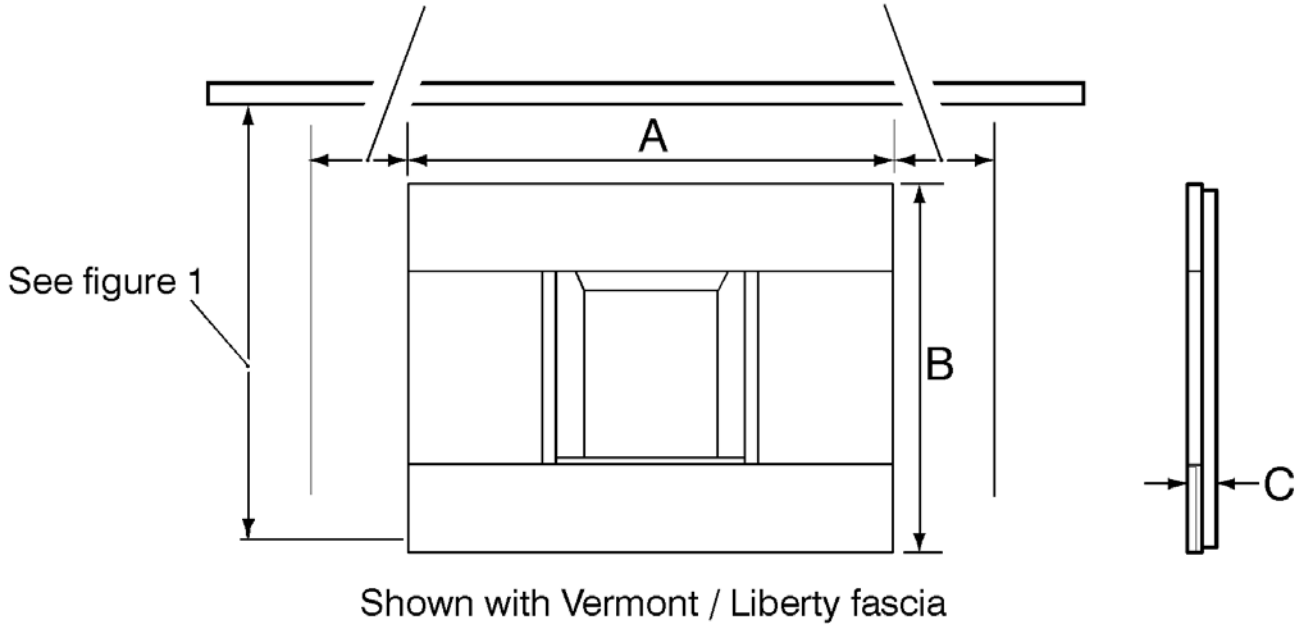

Model	Dimension A	Dimension B	Dimension C
Broadway	1020	626	50
Valor Landscape 2 Gas	1020	626	50
Vermont & Liberty	841	640	61

Figure 2. Appliance dimensions

# OWNER GUIDE

## OPERATING YOUR FIRE

### **PLEASE NOTE**

When operating your fire for the first time, some vapours may be given off which may cause a slight odour and could possibly set off any smoke alarms in the immediate vicinity. These vapours are quite normal with new appliances. They are totally harmless and will disappear after a few hours use.

### **The Oxysafe flame sensing & flue blockage safety system.**

For your safety, this appliance is fitted with a flue blockage safety device which will shut down the appliance in the event of abnormal flue conditions. ***This device is NOT a substitute for an independently mounted Carbon Monoxide detector.*** The device will also automatically shut off the gas supply to the fire if the pilot flame goes out due to lack of oxygen or for any other reason.

***If this device starts to repeatedly shut off the gas, get expert advice.***

This device incorporates a probe which senses that the heat from the pilot flame is correct. If this probe is cool, the device will prevent any gas flow unless the control knob is held in at the ignition position.

If, for any reason, the flames go out when the fire is hot or if the fire is turned off when hot, always ***wait at least three minutes before attempting to relight.***

*This fire may be controlled manually, by use of the controls mounted on the appliance. The flame settings may also be controlled by means of the remote control handset.*

### **Lighting the pilot.**

Please note: The fire must be lit manually.

1. Ensure that the pilot burner control knob is in the OFF position (Number 1 in figure 3).
2. Depress the pilot burner control knob and turn anti-clockwise to the ignition position (Number 2 in figure 3) to activate the piezo ignition system. A 'click' will be heard and the pilot should light. Observe if it is alight by looking through the slots to the left hand end of the front coals. If the pilot does not light immediately, repeat the above procedure, keeping the knob depressed for several seconds in order to purge any air from the system.  
If after ten seconds, ignition has not occurred, turn the control knob back to the OFF position. Wait 30 seconds and then repeat the ignition procedure.
3. When the pilot is alight keep the knob depressed for ten seconds to allow the pilot flame to stabilise.
4. Release the knob. When the knob is released, the pilot should remain alight. If the pilot fails to remain alight, repeat the ignition procedure, this time keeping the knob depressed for a longer period of time.



# OWNER GUIDE

## Heat settings.

1. Once the pilot light is established, light the main burner by turning the pilot burner control knob anti-clockwise to the "main burner on" position (Number 3 in figure 3), and by then turning the main burner control knob to the high position (Number 5 in figure 3).
2. Check the full range of heat settings by turning the main burner control knob slowly between the high position and the low position (Number 4 in figure 3).

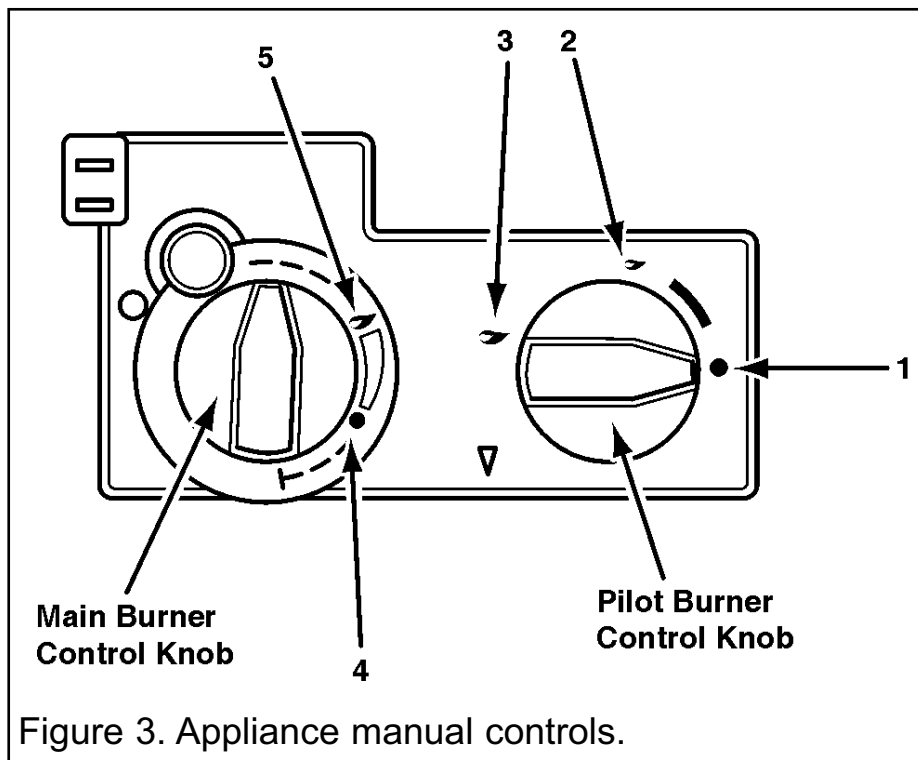

## To turn the fire back to pilot setting.

Turn the main burner control knob fully clockwise. Alternatively turn the pilot burner control knob clockwise to the ignition position (2). Refer to figure 3.

## To turn the fire off.

Rotate the pilot/burner control knob clockwise to position 1, as shown in figure 3.

## Using the remote control handset.

1. Keep the pilot burner at the "main burner on" position. Check the full range of main burner heat settings using the remote control handset. In order to vary the flame effect between High and Low positions, press, and keep depressed, either the High button, or the Low button as appropriate (See figure 4).

The handset operates on ultrasonic principles, and as such it is not necessary to point it directly at the fire.

2. Use the handset to switch to the pilot only setting by depressing the Low button until only the pilot flame remains alight.

3. In order to disable the handset, but still leave the pilot alight, turn the pilot burner control knob to the ignition position (Number 2 in figure 3).

4. Turn the fire off by rotating the pilot burner control knob to the OFF position (Number 1 in figure 3).

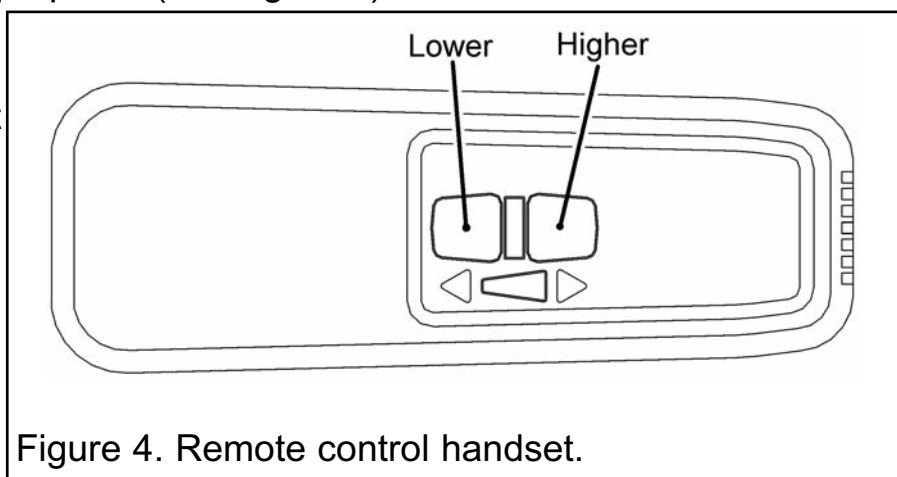

# OWNER GUIDE

## CLEANING YOUR FIRE

To maintain the high performance and quality finish of your Valor Fires appliance, please follow these guidelines:

- Before attempting to clean the fire, please remember to turn off the fire and wait for the appliance to cool completely. The fire will retain heat for some time before cleaning can begin.
- If any pieces of debris are found in the hotbox, have the chimney inspected before further use.

### **Metal parts.**

- Clean the metal parts with a slightly damp, lint free non-abrasive cloth and then dry.
- Do **not** use abrasive cleaners, as these will scratch the fire surface.
- **Broadway & Valor Landscape 2 Gas Fascia** - Clean the metal parts with a slightly damp cloth and then dry.
- **Vermont & Liberty** - Clean the metal parts with a slightly damp cloth and then dry. If this does not work apply a very small amount of 'baby oil' to a lint free, non-abrasive cloth and wipe over the surface. Use a clean cloth to wipe off the oil.

### **Ceramic fuel effect and rear wall.**

- **This product uses fuel effect pieces and burner compartment rear wall containing Refractory Ceramic Fibres (RCF), which are man-made vitreous silicate fibres. Excessive exposure to this material may cause irritation to eyes, skin and respiratory tract. Consequently, it is important to take care when handling these articles to ensure that the release of dust is kept to a minimum.**
- Light coatings of soot will usually be burnt off during the normal operation of the fire.
- Should any soot accumulation become excessive, the fuel effect pieces and walls should be removed from the fire for cleaning.
- Cleaning should be carried out in a well ventilated area or in the open air by gently brushing with the pieces held away from your face so that you avoid inhaling the dust.
- We suggest that you remove the ceramic fuel effect in the reverse order to that shown in the ceramic fuel effect installer and owner guide. This should have been left inside or attached to this guide by the installer.

### **Burner.**

- The burner surface can be carefully cleaned to remove any loose particles after taking off the ceramic fuel effect. Make sure that no particles are pushed into the burner holes.

# OWNER GUIDE

## CERAMIC FUEL EFFECT REFITTING

The installer and owner guide for the ceramic fuel effect is separate from this guide. The installer may have attached it to this guide or placed it inside. It is important that the installer and owner guide for the ceramic fuel effect is followed correctly. If replacing the ceramic fuel effect, where a new guide is supplied, follow the installer and owner guide supplied with the replacement fuel effect.

Keep the replacement installer and owner guide with this owner guide for future reference.

## MAINTENANCE

### **Regular maintenance.**

In order to achieve and maintain high levels of personal safety and performance efficiency, it is essential that the opening at the back of the fire and the flue are kept clear of any form of obstruction. It is possible that deposits of mortar or soot could fall and accumulate causing the flue to be blocked or restricted and so preventing proper clearance of dangerous exhaust fumes.

In the United Kingdom it is the law that a landlord must have any gas appliance, flue and pipework which is situated in a tenant's premises checked for safety at least every twelve months by a competent person (In the UK a GAS SAFE REGISTER engineer, Outside of the UK a CORGI or GAS SAFE REGISTER engineer).

We recommend that all gas appliances and their flues, wherever situated, are checked annually.

### **Replacement ceramics.**

If you wish to replace any of the ceramic fuel effect pieces, spare parts are available nationwide via the '**interpart** stockist network'. For your local stockist consult Yellow pages under Central Heating.

### Standard Warranty Terms & Conditions

The warranty is for 12 months subject to contract.

In the United Kingdom servicing can be carried out either by a **heateam** service engineer or a **GAS SAFE REGISTER** engineer. Outside of the United Kingdom servicing can be carried out either by a **CORGI** or **GAS SAFE REGISTER** engineer. You must register your fire with **heateam**, the service division of Baxi Heating UK Limited, either by completing and returning the registration card or calling our free telephone registration line on **0800 032 72 44**.

It is also a requirement of the warranty that the fire has an annual service (every 12 months) in accordance with the installation and servicing instructions, performed by a **GAS SAFE REGISTER** engineer, (**CORGI** or **GAS SAFE REGISTER** outside of UK), please call on **0844 8711 525**.

### Our promise to you

If you experience a fault with your new fire, we aim to provide a safe and high quality repair service supported by our dedicated national network of highly skilled engineers. If your installer can't resolve the problem for you, we will do everything we can to get an engineer out to you as quickly as possible. Nothing in this warranty will affect your statutory rights.

### What you need to do if you experience a problem with the operation of the fire:

- You should always contact your installer first, because the cause of the fault may not be related to the fire.
- If your installer confirms that the fault is with the fire and they can't repair it, our friendly customer service team is on hand to help.
- Simply call our service division **heateam** on **0844 8711 565** to book an engineer visit or for any general advice that you may need. Our contact centre is open Monday to Friday 8am – 6pm, weekends and Bank Holidays 8.30am – 2pm, excluding Christmas Day and New Years day.

# OWNER GUIDE

When calling **heateam**, it would be helpful if you could have the following information to hand:-

1. Fire serial number and fascia code (Located on the information label - See figure 5 on page 47)\*
2. Date of installation\*
3. Your installer name and address details\*
4. Fire make and model number\*
5. Proof of purchase (if you do not have the fire serial number)

**\*Note: Details 1 – 4 should be recorded on pages 46 & 47 at the end of this guide.**

## **What this warranty covers**

Free of charge repair or replacement of components found to be of faulty manufacture.

Free of charge replacement of the complete unit providing the failure is related to a manufacturing fault that cannot be repaired or is uneconomic to repair.

## **What this warranty does not cover**

Repairs to fires which haven't been installed and commissioned properly and as set out in the installation instructions.

Faults caused by inadequate supply of gas or electricity (where applicable).

Reimbursement of any third party repair or replacement costs that we haven't been told about or agreed with you in advance.

Compensation or consequential losses (e.g. loss of earnings, business losses, stress and inconvenience) arising from a production breakdown, including repair delays caused by factors outside our reasonable control.

# OWNER GUIDE

The following pages are to be completed by the installer:

Installer Details (Block Capitals)

Installer Name	
Gas Safe Register or Corgi Registration Number.	
Company Name.	
Company Address	
Company Telephone number	
Company Fax number	

# OWNER GUIDE

Model

Serial number (Can be found on information label - See figure 5)

A LABEL CONTAINING THE SERIAL NUMBER MAY HAVE BEEN PLACED INSIDE THIS BOX.

Fascia name (Block Capitals)

Fascia code - Can be found on information label (Block Capitals)

A LABEL CONTAINING THE FASCIA CODE MAY HAVE BEEN PLACED INSIDE THIS BOX.

Brand (Please tick)

Baxi

Valor

Wonderfire

Other.....

Date of Installation

D D M M Y Y

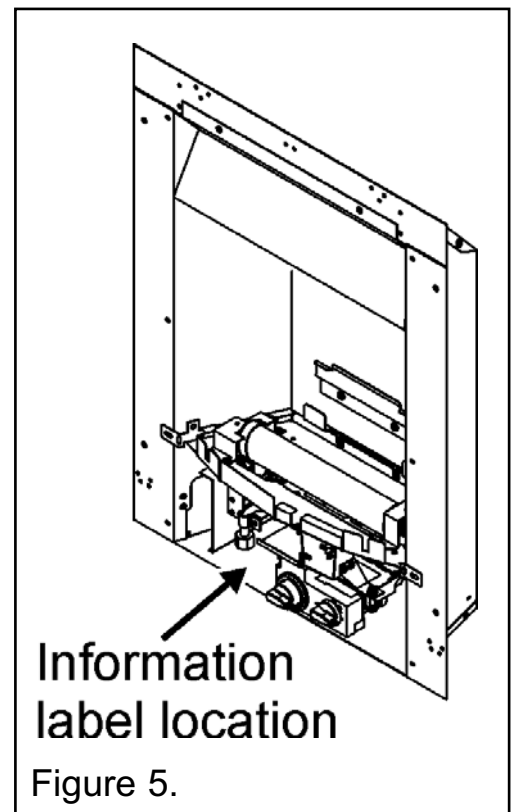

VALOR FIRES